



USS Vulcan

Design Type: Auxiliary

Official Number: AR-5



PRINCIPLE CHARACTERISTICS

BUILDER: NEW YORK SHIPBUILDING CORPORATION

BUILT: 1941

LOA: 529'-4"

BEAM: 73'-4"

DRAFT: 23'-4"

SPEED: 19 KNOTS

PROPULSION: FOUR BOILERS, TWO STEAM TURBINE ENGINES, TWO PROPELLER SHAFTS, 11,000 SHAFT-HORSEPOWER

DISPLACEMENT: 17,000 TONS (FULL LOAD)
9,430 TONS (LIGHTWEIGHT)

COMPLEMENT: 53 OFFICERS
1,244 ENLISTED

ARMAMENT: SINGLE 5"/38 DUAL PURPOSE GUN MOUNTS,
4 .50 CAL MACHINE GUNS
4 TWIN 40MM AA GUNS
4 SINGLE 20MM AA GUNS



NAVY REPAIR SHIP *USS VULCAN*, CIRCA 1941.

THE VULCAN WAS AN AUXILIARY REPAIR SHIP DEPLOYED TO FORWARD AREAS SUPPORTING THE U.S. NAVY. WHEN NOT ENGAGED IN WAR, THE SHIP PROVIDED ASSISTANCE FROM PORTS CLOSE TO THE OPERATIONAL AREAS OF THE ATLANTIC FLEET. VULCAN PARTICIPATED IN WORLD WAR II, THE OCCUPATION OF JAPAN, THE CUBAN MISSILE CRISIS, AND VARIOUS NATO EXERCISES. THE SHIP IS NOTABLE FOR ITS ROLE AS A TEST PLATFORM FOR THE WOMEN IN NAVY SHIPS (WINS) PROGRAM AND FOR HELPING THE NAVY MAKE THE TRANSITION TOWARDS INTEGRATING WOMEN INTO THE FLEET. VULCAN'S FIFTY YEARS OF SERVICE IS A PROVEN TESTAMENT TO THE NECESSITY OF AUXILIARIES IN THE U.S. NAVY.

THE PROJECT WAS PREPARED UNDER THE DIRECTION OF TODD CROTEAU (HAER MARITIME PROGRAM COORDINATOR). ASHLEY WALKER (HAER CONTRACT ARCHITECT) GENERATED VESSEL DRAWINGS. DAVID HAAS (HAER CONTRACT PHOTOGRAPHER) CREATED LARGE FORMAT PHOTOGRAPHS. A SPECIAL THANKS TO ERHARD KOEHLER (U.S. MARITIME ADMINISTRATION) WHOSE HELP AND ASSISTANCE GREATLY BENEFITED OUR PROJECT.

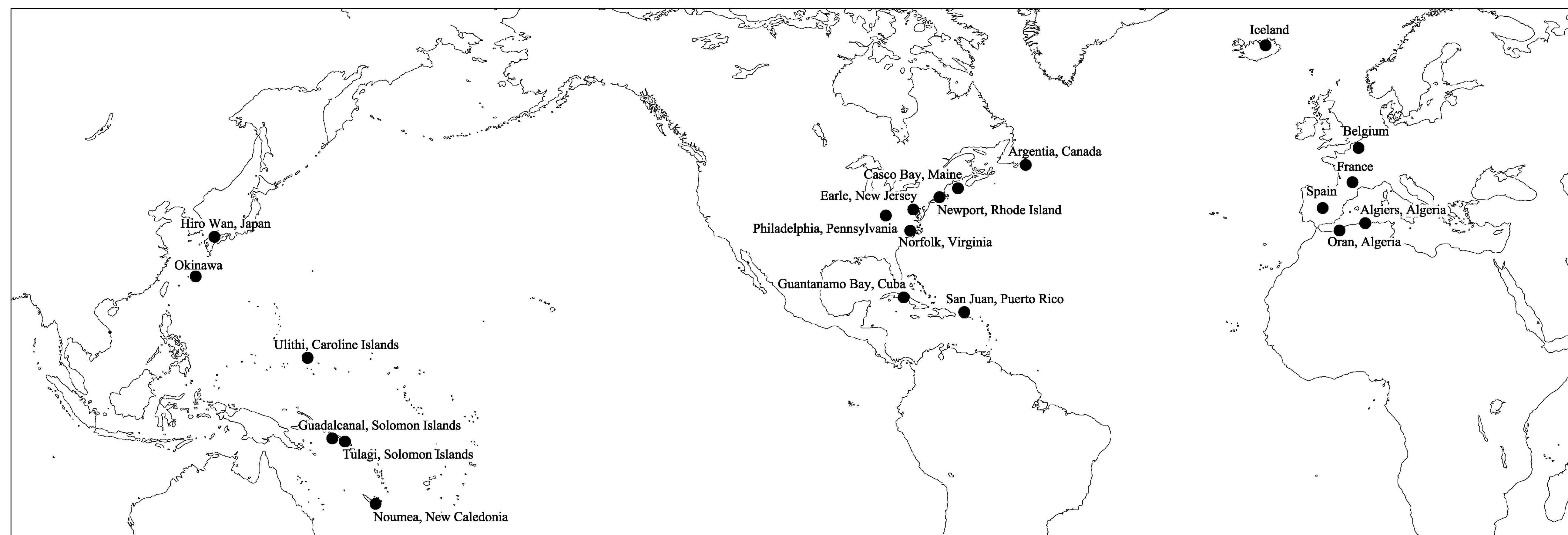

NOTE: PORTS OF CALL

Vulcan

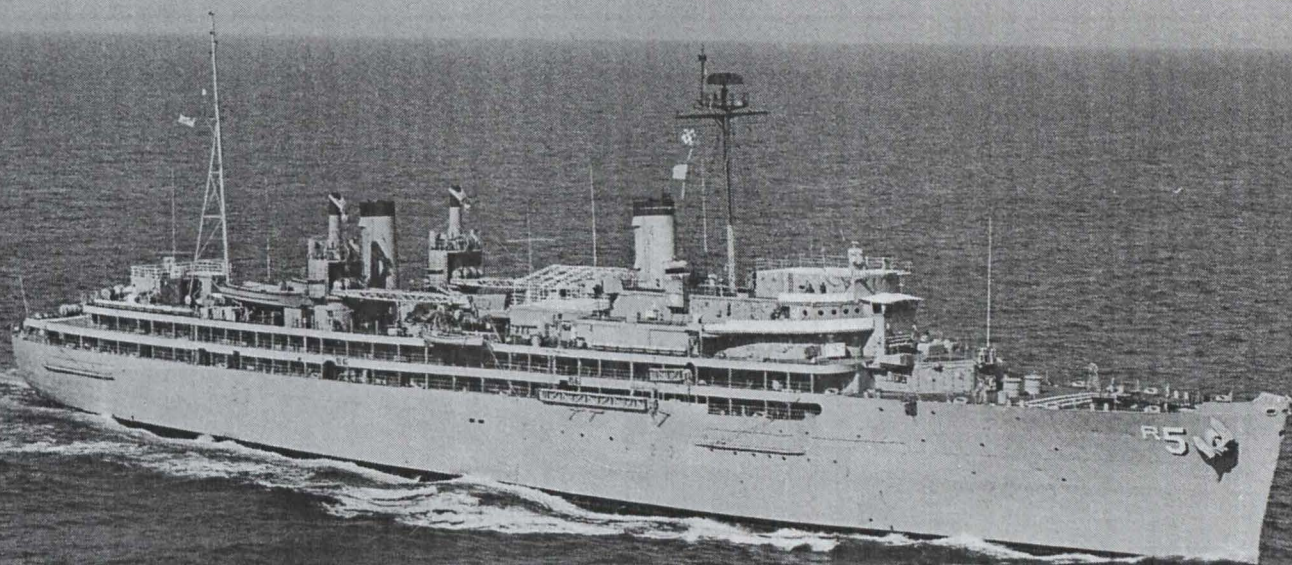

USS *VULCAN*
(AR-5)
James River Reserve Fleet
Newport News vicinity
Virginia

HAER VA-129
HAER VA-129

PHOTOGRAPHS

WRITTEN HISTORICAL AND DESCRIPTIVE DATA

REDUCED COPIES OF MEASURED DRAWINGS

HISTORIC AMERICAN ENGINEERING RECORD
National Park Service
U.S. Department of the Interior
1849 C Street NW
Washington, DC 20240-0001

HISTORIC AMERICAN ENGINEERING RECORD

USS *VULCAN* (AR-5)

HAER No. VA-129

Location: James River Reserve Fleet, Newport News vicinity,
Virginia

Rig/Type of Craft: Auxiliary

Trade: Repair Ship

Class: *Vulcan*

Hull No.: AR-5

Principal Dimensions: Length (oa): 529'-4"
Beam: 73'-4"
Draft: 23'-4"
Displacement: 12,911 (fl) tons
Horsepower: 11,000 shp
Service speed: 19.2 knots
(The listed dimensions are as built, but it should be noted
that draft and displacement were subject to change over
time.)

Dates of Construction: Keel laying: 16 December 1939
Launching: 14 December 1940
Commissioned: 14 June 1941

Designer: U.S. Navy, Bureau of Construction and Repair

Builder: New York Shipbuilding Corporation, Camden, New Jersey

Present Owner: U.S. Maritime Administration

Disposition: Inactive—National Defense Reserve Fleet

Significance: The *Vulcan* is significant as the lead ship in the *Vulcan* class of repair ships, providing assistance to U.S. naval ships from ports close to the occupational areas of the Atlantic Fleet. The *Vulcan* participated in World War II, the occupation of Japan, the Cuban Missile Crisis, and

various NATO exercises during its career. The ship is also notable for its participation as a test platform for the Women in Navy Ships (WINS) program and for helping the U.S. Navy transition toward integrating women in the fleet. The *Vulcan*'s fifty years of service is a testament to the necessity of auxiliaries in the U.S. Navy.

Historian:

Brian Clayton, spring 2008

Project Information:

This project is part of the Historic American Engineering Record (HAER), a long-range program to document historically significant engineering and industrial works in the United States. The Heritage Documentation Programs of the National Park Service, U.S. Department of the Interior, administers the HAER program.

The project was prepared under the direction of Todd Croteau (HAER Maritime Program Coordinator). Ashley T. Walker (HAER Contract Architect) generated the vessel drawings. David Haas (HAER Contract Photographer) produced the large-format photographs. Special thanks go to Erhard Koehler (U.S. Maritime Administration) whose help and assistance greatly benefited this project.

Background

When the United States entered World War II, one of the first priorities was the construction of ships. The global experience and ferocity of World War I taught the United States that World War II would be on a grander scale and in more places, involve more people, and require more equipment, in other words, total war.¹ While building warships was a major concern, the production of auxiliary ships was just as important.² The *Vulcan* class was constructed as part of the buildup of auxiliary ships during World War II. The class included the *Vulcan*, named after the Roman god of fire and patron of metallurgy, along with *Ajax*, *Hector*, and *Jason*.³

Construction

The New York Shipbuilding and Drydock Corporation of Camden, New Jersey, received the contract to construct the *Vulcan* in 1939. The shipyard had been established in 1899 slightly south of Camden, New Jersey, on the east side of the Delaware River. Originally, the company had chosen a location on Staten Island, New York, but a more optimal location was found in Camden before construction began in New York. The company retained “New York” in its name despite the shift in location. The Camden property encompassed 150 acres of land with 4,200' of waterfront acreage and had convenient access to land, rail, and skilled employees. In 1900, the yard began producing various merchant vessels, and in 1906, New York Shipbuilding started constructing warships for the U.S. Navy. The shipyard’s relationship with the navy blossomed during World War I when it began building large capital ships and destroyers. During the inter-war years, New York Shipbuilding constructed commercial passenger liners, cruisers (both heavy and light), and destroyers.⁴

New York Shipbuilding maintained its ties with the navy through World War II and produced several types of warships, including light and heavy cruisers, the fast battleship *South Dakota*, the *Alaska* class (battle cruisers), and light carriers. At the height of production in World War II, the yard employed 35,000 skilled workers and was one of the largest shipyards in the United States. Postwar production continued at the New York Shipbuilding yard as did the relationship with the U.S. Navy. In the latter half of the 1950s, the yard produced a number of carriers, cruisers, and destroyers. In the 1960s, the shipyard made the transition to the nuclear era and began producing frigates and submarines for the navy, along with the first nuclear-powered commercial freighter, the

¹ Russell F. Weigley, *The American Way of War: A History of United States Military Strategy and Policy* (New York, NY: Macmillan Publishing Co., Inc., 1973), pp. xxi-xxiii. Military historians consider World War I to be the first “total” war, in which all available resources were allocated to the war effort.

² The term “auxiliary” refers to support ships that aid other ships in their duties.

³ Robert Gardiner, ed., *Conway’s History of the Ship: The Eclipse of the Big Gun—The Warship 1906-45* (Annapolis, MD: Naval Institute Press, 1992), p. 168. There were two previous vessels in the navy named “Vulcan.” The first was in service from 1898-1899 as a repair ship. The second *Vulcan* was a coal ship in operation from 1909 to 1923.

⁴ Robert J. Winklareth, *Naval Shipbuilders of the World: From the Age of Sail to the Present Day* (London, UK: Chatham Publishing, 2000), pp. 187-189; “New York Ship Building,” available at <http://www.globalsecurity.org/military/facility/camden.htm>, accessed January 2011.

NS *Savannah* (see HAER No. DC-64). New York Shipbuilding also received the contract to build the conventional carrier, USS *Kittyhawk* (CV-63) in the early 1960s, but the navy's shipbuilding budget shrank in the late 1960s, and the shipyard suffered as a result. It produced its last vessel, the submarine USS *Guardfish* (SSN-612), in 1967.⁵

Design and Engineering Features

The navy followed the production techniques developed by the Maritime Commission of designing auxiliary ships with a universal hull that could later be converted into destroyers, submarine tenders, and repair ships. The *Vulcan* class design was based on two requirements: a light displacement around 10,000 tons and a speed of 19 knots. The ships measured 529'-4" in overall length and 73'-4" amidships, with a limiting draft of 23'-4". The numerous tanks in the inner bottom, bow, and stern carried fuel oil and water that served as ballast. The ship held 25,420 barrels of fuel, allowing a maximum cruising radius of 15,000 nautical miles. As the ship consumed fuel, pumps within the machinery room transferred seawater into the empty tanks to maintain the correct stability and trim.⁶

To achieve the designed speed of 19 knots, the ship had two power plants rated at 11,000 shaft horsepower (shp) to turn two screws. There were two machinery spaces on the second platform, one forward of the auxiliary machine room and one aft but located forward of the aft storerooms. Inside each machinery space were two Babcock and Wilcox boilers for each turbine. The forced draft boilers burned oil to create steam at 720 degrees Fahrenheit producing 400 psi. Steam pipes fed into the two turbines built by the New York Shipbuilding Corporation that generated 5,500-horsepower (hp) apiece to turn each shaft. Two evaporators for the air conditioning system and six generator sets for on-board power were located in the auxiliary machinery room. Extensive ductwork for the air conditioning system extended throughout the ship to keep the crew quarters and workspaces cool. Just as important as the propulsion plant were the generators, which were steam turbine units that generated 750 kilowatts of power or 450 volts of AC. The ship required a significant amount of power for its machinery to operate on all the deck levels as well as for the navigation equipment.

The bridge deck housed a number of rooms related to the navigation and safety of the vessel. The wheelhouse was in the forward room with an engine order telegraph, gyro

⁵ Winklareth, *Naval Shipbuilders*, pp. 187-189; "A Brief History of the New York Shipbuilding Company."

⁶ This description is based on the following sources. Gardiner, *Conway's History of the Ship*, p. 168; U.S. Navy, *Ship's Data: U.S. Naval Vessels*, Vol. III (Washington, DC: Government Printing Office, 1946), pp. 324-325, 327; U.S. Navy, "Vulcan," in *Dictionary of American Naval Fighting Ships* Vol. VII (Washington, DC: Naval Historical Center, 1981), pp. 566-567; and U.S. Navy, Ships' Plan, "USS *Vulcan*," in Record Group 19, National Archives and Records Administration—College Park, Maryland. These plans include: Navy Department, Bureau of Construction & Repair, Washington, DC, "U.S. Repair Ship AR-5, Inboard Profile," Contract Plan No. 3, C&R 305044, May 29, 1939; "US Repair Ship AR-5, Main, Upper, and Superstructure Decks and Bridge," Contract Plan No. 5, C&R 305046; "US Repair Ship AR-5, Half, Second, and Third Decks," Contract Plan No. 6, C&R 305047; and "US Repair Ship AR-5, First & Second Platforms and Hold," Contract Plan No. 7, C&R 305048. Copies of these drawings are included with the field records accompanying this documentation.

repeater, and helm, which sent electric signals to the steering room where an electric-hydraulic ram turned the rudder. Two bridge wings extended off each side complete with alidades and searchlights. The chartroom was located aft of the wheelhouse. The coding and radio room was on the same level but in a separate space on the port side. There were five berths for the ship's officers and a sea cabin for the captain. In the aft section of the bridge were three repair rooms for small equipment, such as projectors, typewriters, and watches.

Since the *Vulcan* was a repair ship, a majority of the space onboard was for the manufacture and refurbishment of equipment. The second platform held a number of spaces for stowing foundry and machine shop equipment. The first platform contained an electrical workshop and a foundry used to cast metal parts. A travel crane on the third deck above the foundry was used to hoist parts, while storerooms contained battery equipment and lumber, among other things. Forward of the foundry were two repair shops for hydraulics and refrigeration. The second deck consisted of the metals department with the boiler, sheet metal, and ship fitters shops. The second deck also housed a blacksmith shop and a machine shop where basic parts could be crafted. The machine shop office and main issue room were in the forward section of the ship on the same level. The main deck included an aviation shop, carpenter and pattern shop, gage repair, grinding and auxiliary machine sections, a machine shop gallery, and a tool issue room. The upper deck encompassed a battery repair room, communication instrument shop, fire control instrument shop, gyrocompass repair shop, a small boat engine repair and machine shop, and a welding shop for pipe and copper. The superstructure deck housed an optical and rangefinder shop, including machine shops to manufacture and repair armament equipment.

The *Vulcan* carried four cranes in two sizes as well as two booms that could hoist and position material for loading or offloading. Two heavy electric cranes (20-ton) were located on the stern section of the ship and served a dual purpose; they could move and position deck equipment as well as lift and lower materials, machines, and supplies through three removable hatches in the superstructure deck. Two light electric cranes (5-ton) on the forward superstructure helped move and position light equipment, stores, and supplies. Two additional booms for moving light equipment and supplies were on the aft superstructure, and the crew operated these with ropes and electric winches. The deck equipment was mirrored on the port and starboard sides of the ship.

The berthing space for the crew, totaling 1,297 personnel, fifty-three of which were officers and the rest were enlisted, occupied a sizable amount of space on the ship. The deck officers were on the bridge deck, while the remaining shipboard officers lived in the forward areas of the upper and main decks. Berths for the Chief Petty Officers (CPO) were in the forward section of the ship on the half deck, while the enlisted crew occupied the stern section from the third deck to the upper deck in bunks stacked three high.⁷

⁷ Ships' Data, p. 325; Ships' Plan.

Food service took place in three areas on the ship, and there were ample food storage spaces to accommodate long deployments. Food preparation took place in the forward area on the third deck, and there were spaces for a bakery, butcher shop, and vegetable preparation area. The crew's galley lay off to the side, while the mess was on the second deck, above the food preparation space. Mess attendants served the crew cafeteria-style from steam tables, and seating occupied all of the forward area on the second deck. The CPO mess was on the half deck adjacent to their quarters. Officers used two separate dining areas: warrant officers had a small mess in the forward section on the main deck next to a second galley while commissioned officers had a wardroom on the upper deck adjacent to their quarters. Food storage was on the first platform in three separate lockers that contained butter, eggs, and cheese in one, fruit and vegetables in another, and meat in the third. The lockers were beneath the crew's galley and were accessed by stairs within a truck.

Good hygiene and morale were important aspects of shipboard life. Therefore, there was sufficient space for showers, toilets, and washrooms near the crew's living quarters. Dental and medical offices staffed by doctors were located in the forward area of the main deck. A barbershop with three chairs was located in the forward area on the third deck. Laundry facilities were on the same deck for processing clothes and linens. A small area on the third deck was set aside to serve as a recreational space to help pass monotonous days while the ship was underway. A PX store was available for the crew to purchase personal items, and there was also a post office and chaplain's office in the forward area.

During World War II, defensive armament was installed on the ship. On the bow were two 5"/38 single-mount guns with two more on the stern section. The 5"/38s were dual purpose, targeting aircraft and ships. Four double-barrel, 40-millimeter anti-aircraft Bofors were on the superstructure. Ammunition trunks were in the hold under the 5"/38s, and hoists lifted the powder and shells upward for the gunners. In the event of a sinking, there were multiple lifeboats and rafts onboard. Motorized lifeboats were on the stern section of the ship, and rafts hung off the sides of the ship on the main deck.

Operational History

The *Vulcan* was commissioned at the Philadelphia Naval Yard on 14 June 1941 and began operations in the Atlantic. The ship underwent sea trials in the Caribbean and made ports of call in San Juan and Guantanamo Bay. After undergoing repairs at the Philadelphia Naval Yard, the ship set out at the end of August for Argentina, Newfoundland, via Casco Bay, Maine, for its first deployment.⁸

⁸ The operational history is based on the U.S. Navy, *Dictionary of American Naval Fighting Ships*, pp. 566-567, also available online at <http://www.history.navy.mil/danfs/v4/vulcan-iii.htm>, accessed October 2006, and "USS *Vulcan* (AR-5) Collection History," available at <http://www.lib.odu.edu/specialcollections/manuscripts/vulcan.htm>, accessed 11 March 2008. Old Dominion University's Special Collections contains material on the ship in the USS *Vulcan* (AR-5) Collection, MG-57.

The second mission took the ship to Iceland in spring 1941 as part of Task Force 4, a which was a group of seven navy vessels centered on the aircraft carrier *Wasp* (CV-7). Task Force 4 was charged with defending the Atlantic in case the German battleship *Tirpitz* maneuvered away from its base. Military planners were concerned about the movements of the *Tirpitz* because the *Bismarck* had broken out the previous spring. The U.S. Navy's contingency plan ordered Task Force 4 to the area to monitor the *Tirpitz*, but it never left the base. Meanwhile, the *Vulcan* remained in the Atlantic and continued operations out of Iceland.

The German U-boats proved to be more of a problem for ships sailing in the Atlantic, and the *Vulcan's* repair facilities assisted war-damaged ships as well as those that suffered accidental mishaps. The *Vulcan's* first customer was the USS *Kearny* (DD-432), a destroyer damaged by a U-boat on 17 October 1941. The *Kearny* had been screening a fleet of vessels in a convoy when U-568 fired a torpedo that struck the ship below the waterline on the starboard side. The *Vulcan* ordered the destroyer to flood its port tanks and repaired the exposed torpedo hole by welding a patch over the hull. The *Kearny* left Iceland for the United States at the end of December for comprehensive repairs.

In November 1941, the *Vulcan* repaired a second destroyer that had collided with a Norwegian cargo ship. The *Niblack* (DD-424), on patrol in inclement weather, collided with the freighter. As a result of the collision, the *Niblack's* anchor was torn off, and the hull was punctured. The *Vulcan* patched the hull, and the destroyer returned to convoy escort duty.

On 2 May 1942, the *Vulcan* arrived in Boston, Massachusetts, for minor repairs and then headed back to Iceland via Argentia, Newfoundland. The ship arrived at Argentia on 16 June and departed on 14 November for Hvalfjordur to relieve the destroyer tender *Melville* (AD-2). A few days later, it arrived, remaining there until 6 April 1943 when it returned to the Norfolk Naval Base. The *Vulcan* underwent repairs in dry dock before sailing to the Mediterranean at the end of June. From 8 June through 22 June 1943, the *Vulcan* sat in dry dock at the Norfolk Naval Shipyard and underwent modifications. The next stop for the ship was Oran, Algeria, on 27 June and then Algiers at the end of that month.

While in Algiers, the *Vulcan's* crew assisted the *Arrow*, a British ammunition ship that had caught fire. The *Vulcan* sent a fire control party to assist the British crew along with a second boat crew to rescue sailors trapped beneath the decks. The boat crew used a torch to cut through the side of the ship and rescue the British crewmembers. Three sailors from the *Vulcan* received medals for valor in the face of danger.

For the rest of the summer and into the fall of 1944, the *Vulcan* stayed in the Mediterranean assisting ships in need of repair. In August and September, the ship provided assistance as the Allies invaded southern France. The *Vulcan* repaired damaged vessels participating in the operation and earned a battle star for its efforts.

The ship's next assignment was in the Pacific, repairing ships participating in the island-hopping campaigns during the last stages of the war. The *Vulcan* crossed the Atlantic in November 1944 and arrived in Norfolk, Virginia, for repairs, remaining there until January 1945. The ship next set off for the South Pacific in February, with the first stop at Guadalcanal. Continuing up the chain of islands, the *Vulcan* conducted repairs out of Tulagi, Noumea, and Ulithi until the war ended in summer 1945.

After World War II, the *Vulcan* operated out of Okinawa for a short time before transferring to the Japanese home islands to assist vessels in the occupation. The *Vulcan*'s first major duty was the repair of ships damaged in a violent typhoon. While repairs were underway, a second typhoon hit the area, and the *Vulcan* guided seventeen ships out of anchorage to safety at the end of September 1945. The following month, the *Vulcan* set sail for Hiro Wan, Japan, and set up an advanced base for ships involved in the occupation force. The ship furnished food, oil, and water to the group and constructed services to handle mail and provide medical assistance and recreation opportunities on shore. Additionally, the ship serviced the minesweepers clearing mines in Japanese waters. At the beginning of March 1946, the *Vulcan* set sail for the United States and arrived the following month at its new homeport of Newport, Rhode Island. The ship remained there for eight years before transferring to Norfolk.

For the duration of its career, the *Vulcan* remained home ported at Norfolk, Virginia, operating off the East Coast repairing ships for the Atlantic Fleet. Deployments ranged from the Caribbean to Canadian ports. During the Cuban Missile Crisis, the *Vulcan* supported the ships involved in the blockade while based out of San Juan, Puerto Rico. The ship participated in two NATO exercises in fall 1964 and made ports of call in Belgium, France, and Spain before returning to Norfolk where it underwent a major overhaul in 1976. The work included removal of the 5" guns and replacement with four 20-mm guns.

The U.S. Navy chose the *Vulcan* as its test platform for the Women in Navy Ships (WINS) program. On 1 November 1978, women officers reported to the *Vulcan* for duty, and in December 1978 and January 1979, enlisted women followed. The *Vulcan*'s first cruise with the newly-integrated crew took place in February when the ship traveled from Norfolk, Virginia, to Earle, New Jersey. In September 1979, the ship deployed to the Mediterranean. The success of the cruise promoted the WINS program and led to the incorporation of more women aboard navy ships. Before the ship's decommissioning, women constituted one-seventh of the total crew.

During the 1980s, the *Vulcan* continued operations off the East Coast and made several deployments overseas. In 1980, for example, the ship joined in a NATO exercise called "Teamwork 80" with ships from Britain, Holland, and West Germany. The ship underwent a major refit in February 1983 that lasted thirteen months. The *Vulcan* continued operating with the Atlantic fleet until October 1984, when it was deployed to

Diego Garcia. The ship then returned to the East Coast and resumed normal duties as an Atlantic Fleet repair ship based out of Norfolk, Virginia.

The U.S. Navy decommissioned the ship in 1991 after fifty years of service and turned it over to the U.S. Maritime Commission. The *Vulcan* was housed with the James River Reserve Fleet for over fifteen years until Bay Bridge Enterprises of Chesapeake, Virginia, acquired it for scrapping. On 19 December 2006, the Maritime Administration released the ship from the fleet, and a tug towed it down river for dismantling.

Conclusion

The *Vulcan* was notable for its longevity as a repair ship while serving in the U.S. Navy and for participating in the WINS program that helped change the course of U.S. naval history by integrating women into the fleet.

Appendix A: Historic Images



Figure 1: Caption reads: AR 5, Port Bow, Norfolk Navy Yard, Photo Serial 9559 (45), Jan. 10, 1945. From Photographic Section, Naval History & Heritage Command, Washington, DC.



Figure 2: No caption or date. Photograph shows the *Vulcan* underway. From Photographic Section, Naval History & Heritage Command, Washington, DC.



Figure 3: No caption or date. Photograph shows the *Vulcan* underway. From Photographic Section, Naval History & Heritage Command, Washington, DC.

Select Bibliography

- Gardiner, Robert, ed. *Conway's History of the Ship: Eclipse of the Big Gun – The Warship 1906-45*. Annapolis, MD: Naval Institute Press, 1992.
- U.S. Navy, Ships' Plan "USS *Vulcan*." Record Group 19, National Archives and Records Administration—College Park, MD.
- U.S. Navy. "Vulcan," in *Dictionary of American Naval Fighting Ships*. Vol. VII. Washington, DC: Naval Historical Center, 1981.
- _____. *Ships' Data U.S. Naval Vessels: Auxiliary, District Craft, and Unclassified Vessels*. Vol. III. Washington, DC: Government Printing Office, 1946.
- Weigley, Russell F. *The American Way of War: A History of United States Military Strategy and Policy*. New York, NY: Macmillan Publishing Co., Inc., 1973.
- Winklareth, Robert J. *Naval Shipbuilders of the World: From the Age of Sail to the Present Day*. London, UK: Chatham Publishing, 2000.

HISTORIC AMERICAN ENGINEERING RECORD

INDEX TO PHOTOGRAPHS

USS *VULCAN*

(AR-5)

James River Reserve Fleet

Newport News vicinity

Virginia

HAER VA-129

INDEX TO BLACK AND WHITE PHOTOGRAPHS

David Haas, photographer, 2008

| | |
|----------|---|
| VA-129-1 | Bow view. |
| VA-129-2 | Stern view. |
| VA-129-3 | Starboard side of ship, view toward bow. |
| VA-129-4 | Port side deck view, looking aft. |
| VA-129-5 | View of fore deck. |
| VA-129-6 | Mid-deck view, looking forward. |
| VA-129-7 | Mid-deck view, looking aft. |
| VA-129-8 | View of bridge, looking aft. |
| VA-129-9 | Detail of ghosting of turret mount on aft deck. |

HISTORIC AMERICAN ENGINEERING RECORD
SEE INDEX TO PHOTOGRAPHS FOR CAPTION

HAER No. VA-129-1

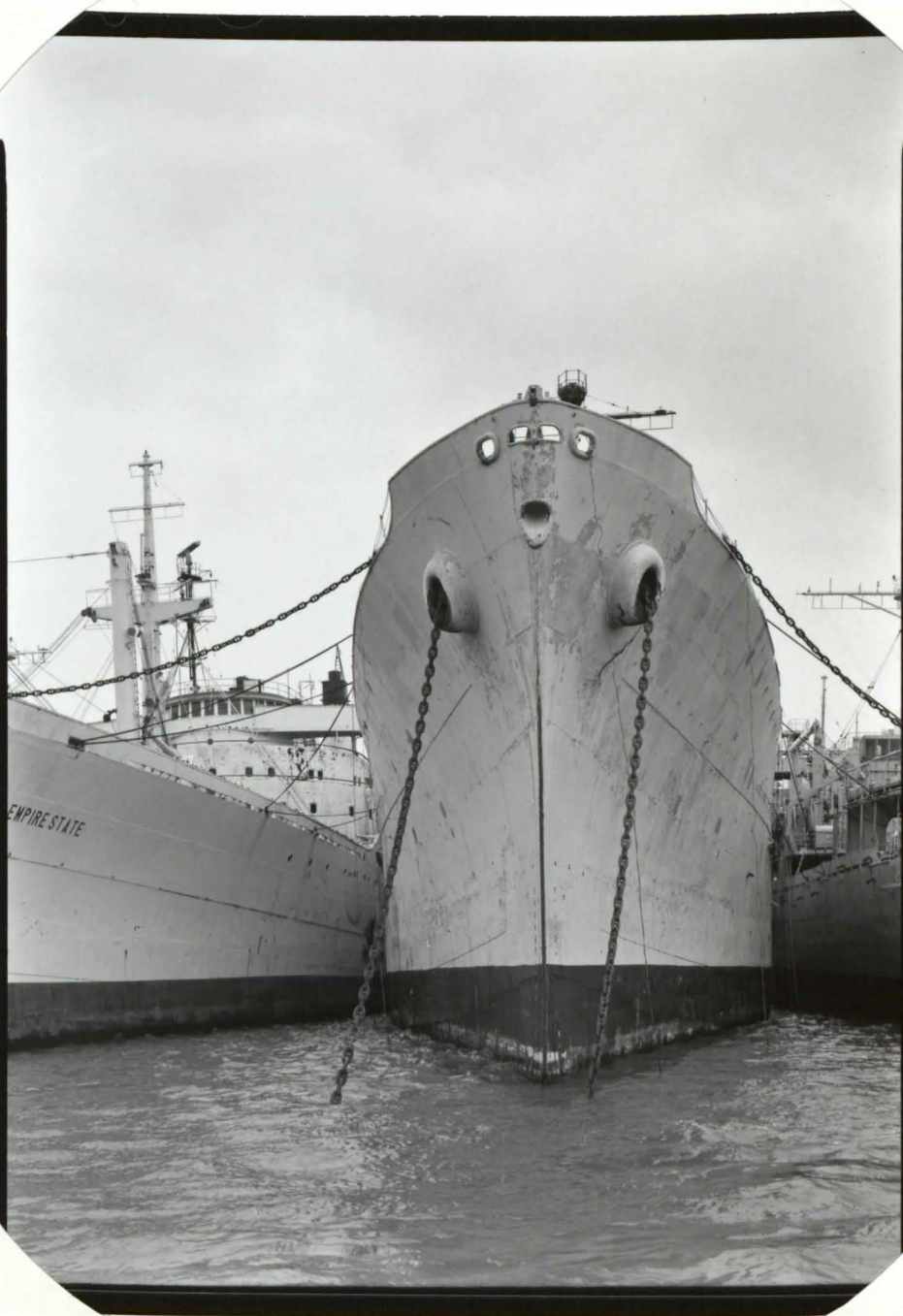

HISTORIC AMERICAN ENGINEERING RECORD
SEE INDEX TO PHOTOGRAPHS FOR CAPTION

HAER No. VA-129-2



HISTORIC AMERICAN ENGINEERING RECORD
SEE INDEX TO PHOTOGRAPHS FOR CAPTION

HAER No. VA-129-3

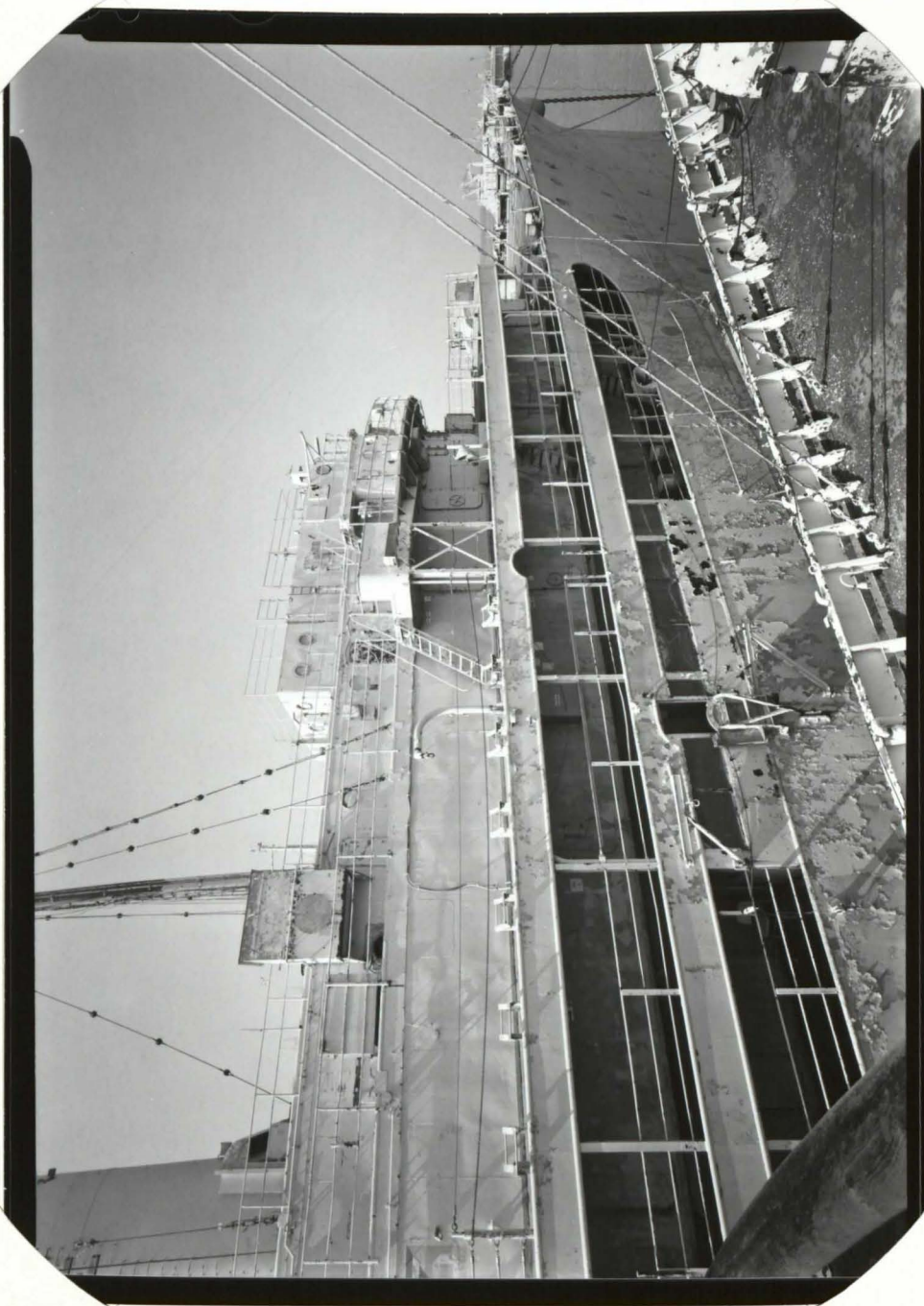

HISTORIC AMERICAN ENGINEERING RECORD
SEE INDEX TO PHOTOGRAPHS FOR CAPTION

HAER No. VA-129-4



HISTORIC AMERICAN ENGINEERING RECORD
SEE INDEX TO PHOTOGRAPHS FOR CAPTION

HAER No. VA-129-5

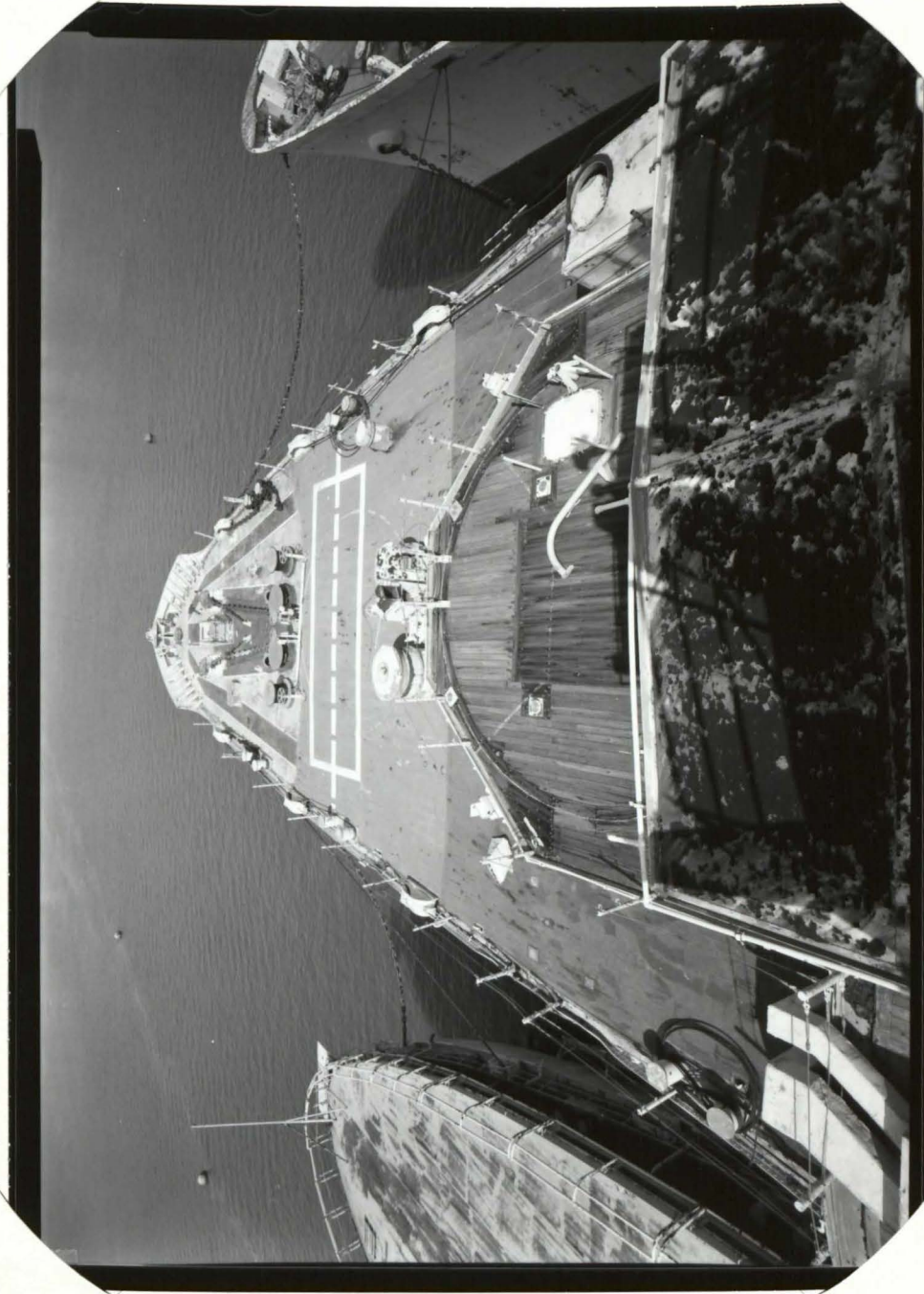

HISTORIC AMERICAN ENGINEERING RECORD
SEE INDEX TO PHOTOGRAPHS FOR CAPTION

HAER No. VA-129-6

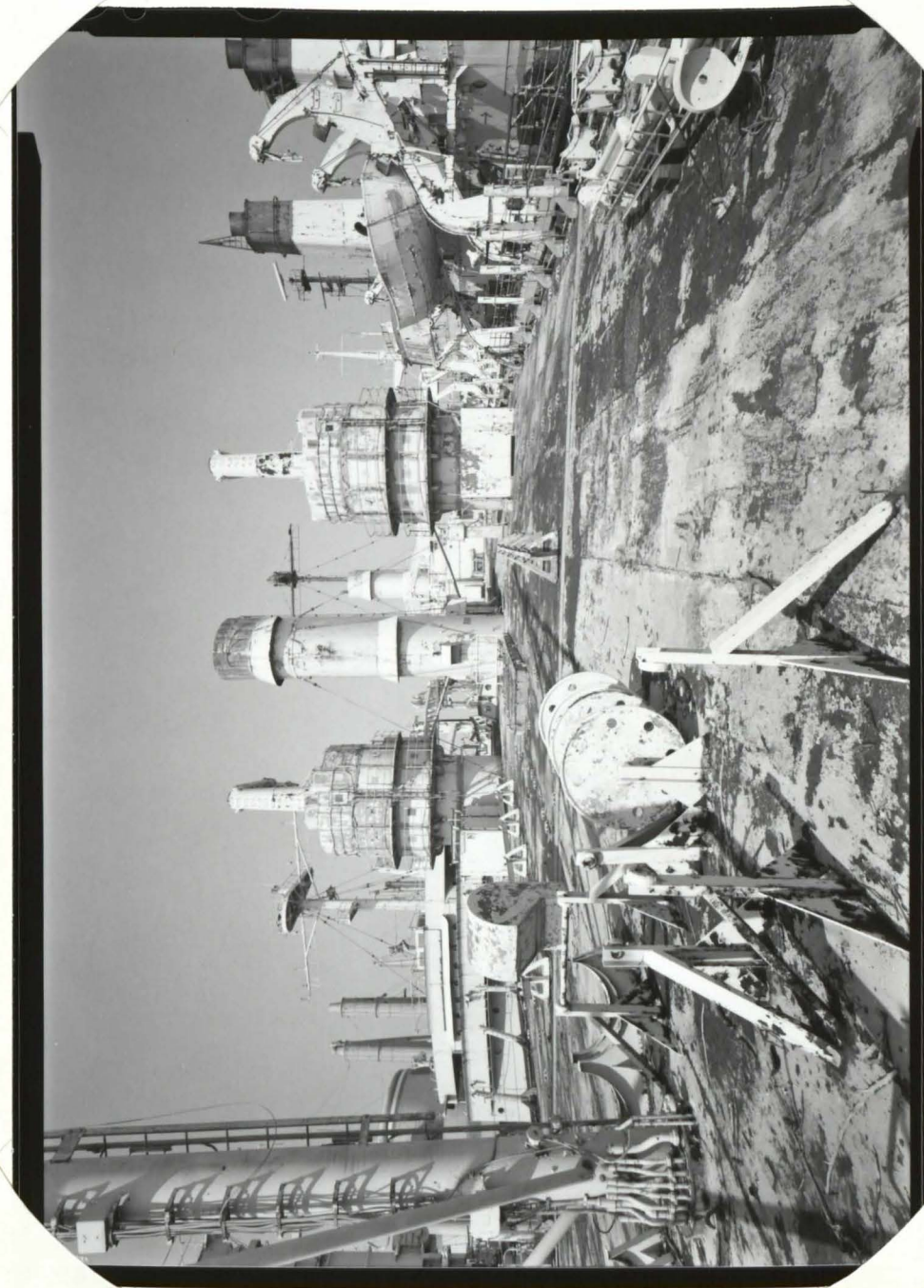

HISTORIC AMERICAN ENGINEERING RECORD
SEE INDEX TO PHOTOGRAPHS FOR CAPTION

HAER No. VA-129-7



HISTORIC AMERICAN ENGINEERING RECORD
SEE INDEX TO PHOTOGRAPHS FOR CAPTION

HAER No. VA-129-8



HISTORIC AMERICAN ENGINEERING RECORD
SEE INDEX TO PHOTOGRAPHS FOR CAPTION

HAER No. VA-129-9



USS Vulcan

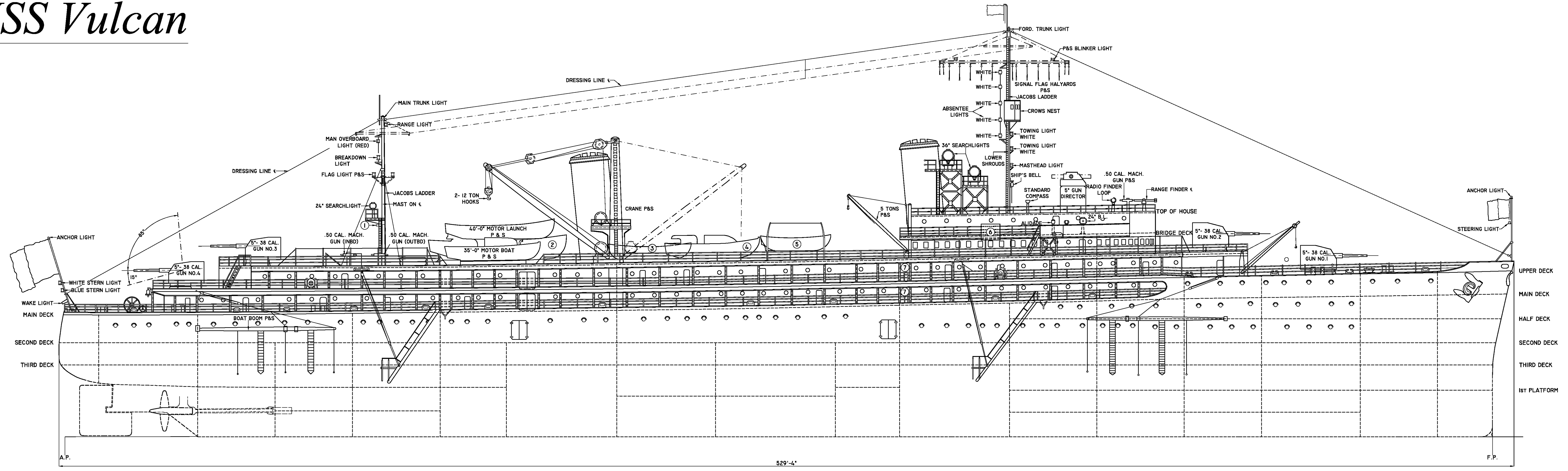

OUTBOARD PROFILE

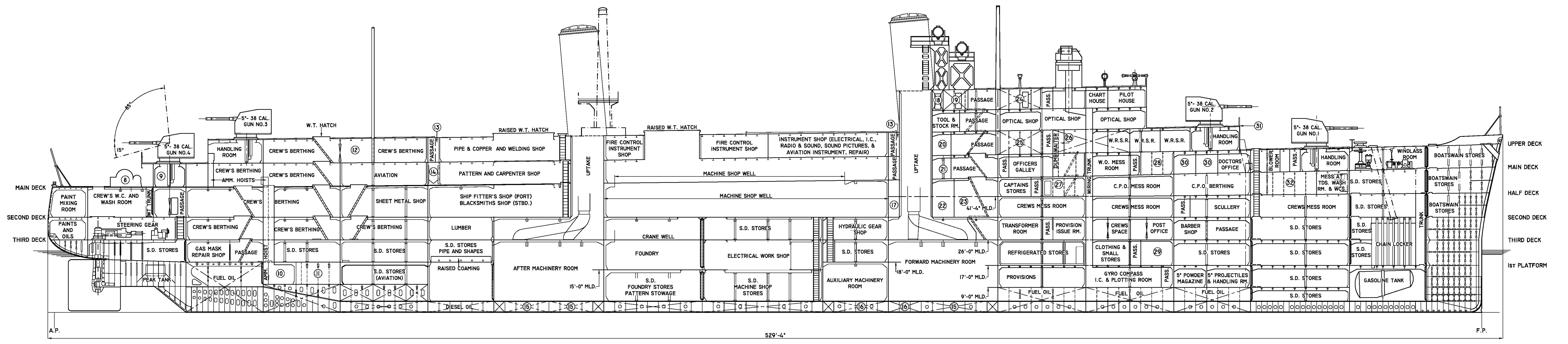

INBOARD PROFILE

NOTE: DRAWINGS TRACED FROM SCANS OF ORIGINAL DESIGN DRAWINGS (GENERAL ARRANGEMENTS MC1919-S33-I-15)

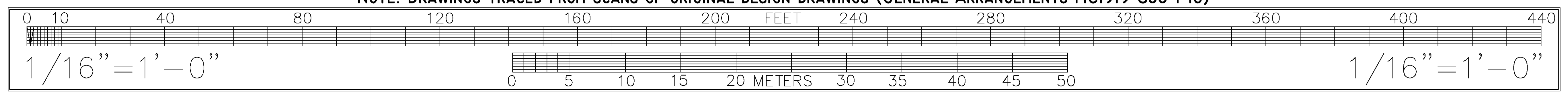

SCHEDULE OF ROOMS & FEATURES OF VESSEL

| NO. | NAME/ TITLE | NO. | NAME/ TITLE | NO. | NAME/ TITLE | NO. | NAME/ TITLE | NO. | NAME/ TITLE |
|-----|--|-----|--------------------------------------|-----|------------------------------------|-----|---|-----|---|
| 1 | SCREENED SPEED LIGHT | 7 | PASSAGE | 13 | EXPANSION JOINT | 19 | RADIO CENTRAL (PORT) BHD. ON CENTER LINE | 25 | W.R.W.C. AND SHOWERS (PORT) BHD. ON CL. |
| 2 | 50'-0" MOTOR LAUNCH P&S | 8 | TOWING ENGINE | 14 | SLIDING DOOR PASSAGE | 20 | WARD ROOM PANTRY | 26 | CONFIDENTIAL LOCKER |
| 3 | 30'-0" WHALE BOAT STARBOARD ONLY | 9 | HANDLING ROOM | 15 | RESERVE FEED WATER | 21 | BLOWER SPACE | 27 | ARMORY BHD. ON CENTER LINE |
| 4 | 35'-0" MOTOR BOAT STARBOARD ONLY | 10 | HANDLING ROOM & PROJ. STOWAGE | 16 | POTABLE WATER | 22 | AIR COOLING COMPRESSOR | 28 | BH. ON CL. WARRANT OFFICERS S.R. PORT |
| 5 | 26FT MOTOR WHALE BOAT PORT & STARBOARD | 11 | 5" POWDER ROOM SMALL ARMS AMM. STBD. | 17 | REPAIR PARTY LOCKER | 23 | MAIN ISSUE ROOM (PORT) | 29 | CLOTHING AND SMALL STORES ISSUE ROOM |
| 6 | SIGNAL FLAG BOARD P&S | 12 | RADIO TRANSMITTER ROOM | 18 | GEN. ROOM PORT BHD. ON CENTER LINE | 24 | MAIN COMMUNICATION STATION (PORT) BHD. ON CL. | 30 | WARRANT OFFICES S.R. |
| | | | | | | | | 31 | SUPERSTRUCTURE DECK |
| | | | | | | | | 32 | C.P.O. WASHROOM AND WATER CLOSETS PORT |

USS Vulcan

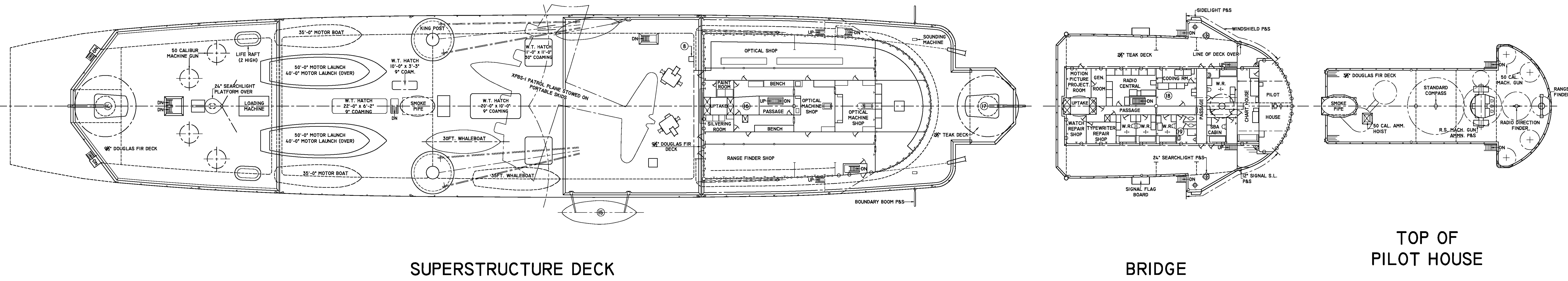

SUPERSTRUCTURE DECK

BRIDGE

TOP OF PILOT HOUSE

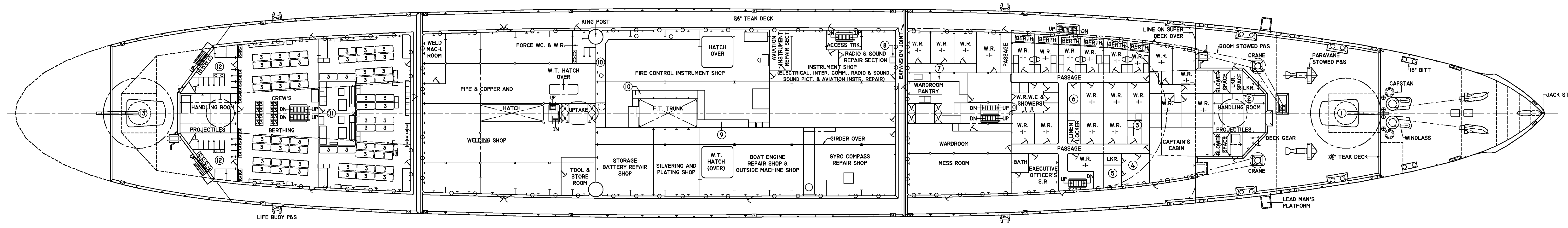

UPPER DECK

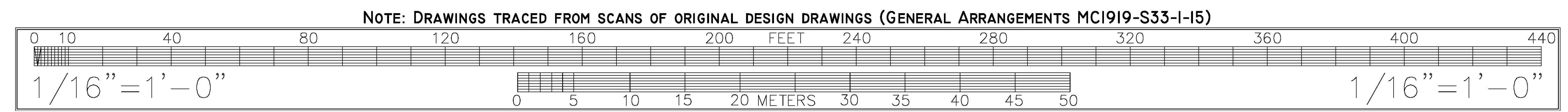

| SCHEDULE OF ROOMS & FEATURES OF VESSEL | | | | | | | | | |
|--|------------------------|-----|-----------------------------------|-----|-------------------------|-----|---|-----|----------------------------|
| NO. | NAME/ TITLE | NO. | NAME/ TITLE | NO. | NAME/ TITLE | NO. | NAME/ TITLE | NO. | NAME/ TITLE |
| 1 | 5" 38 CALIBER GUN NO.1 | 5 | CAPTAIN'S BATHROOM | 9 | MACHINIST WORK BENCH | 13 | 5" 38 CALIBER GUN NO.4 | 17 | 5" 38 CALIBER GUN NO.2 |
| 2 | 3" R.S. POWDER | 6 | CONFIDENTIAL LOCKER | 10 | FIRE CONTROL WORK BENCH | 14 | 5" 38 CALIBER GUN NO.3 | 18 | MAIN COMMUNICATION STATION |
| 3 | CAPTAIN'S PANTRY | 7 | DISHWASHER MACHINE AND STERILIZER | 11 | RADIO TRANSMITTER ROOM | 15 | 26FT. MOTOR WHALEBOAT STOWED OUTBOARD P&S | 19 | W.R. W.C. AND SHOWERS |
| 4 | CAPTAIN'S S.R. | 8 | 24"x 24" CHUTE TO INCINERATOR | 12 | CREWS W.C. AND SHOWER | 16 | ORPHANAGE TOOLS AND STOCK | | |

USS Vulcan

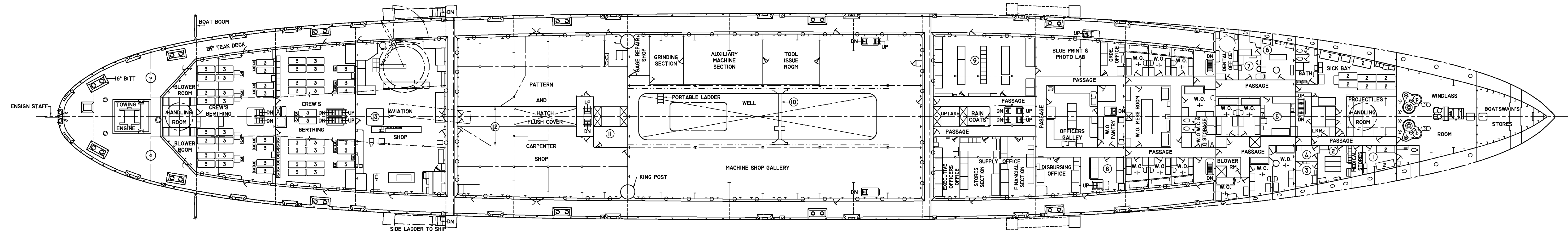

MAIN DECK

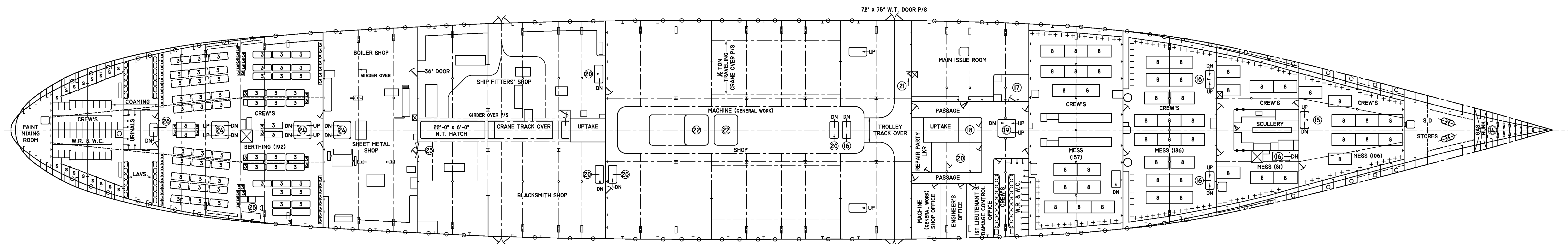

SECOND DECK

NOTE: DRAWINGS TRACED FROM SCANS OF ORIGINAL DESIGN DRAWINGS (GENERAL ARRANGEMENTS MCI919-S33-I-15)

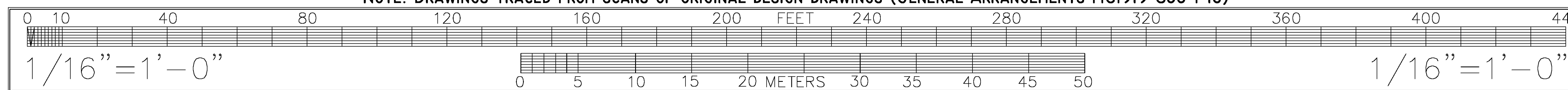

SCHEDULE OF ROOMS & FEATURES OF VESSEL

| NO. | NAME/ TITLE | NO. | NAME/ TITLE | NO. | NAME/ TITLE | NO. | NAME/ TITLE | NO. | NAME/ TITLE | NO. | NAME/ TITLE |
|-----|-------------------------------|-----|---|-----|---|-----|---|-----|---------------------------------|-----|-------------------|
| 1 | ISOLATION WARD | 6 | SURGICAL DRESSING ROOM | 11 | CARPENTER TOOL & STORE ROOM | 16 | 36" x 72" A.T. | 21 | W.T. DOOR 18" x 36'-9" SILL | 26 | 30" x 54" OPENING |
| 2 | OPERATING ROOM | 7 | TREATMENT ROOM | 12 | KEEP CLR. OF FIXED TOOLS FOR HANDLING PLANE FLOATS TO AVIATION SHOP | 17 | GARBAGE UNLOADING PLATFORM | 22 | 8'-0" x 10'-0" P.N.T.H. | | |
| 3 | STERILIZATION ROOM | 8 | CAPTAIN AND NAVIGATORS OFFICE | 13 | H.T. HATCH 6'-0" x 6'-0" | 18 | AIR COOLING COMPRESSOR | 23 | DOOR WITH 4'-0" BOLTED FRAME | | |
| 4 | SCRUB ROOM | 9 | REPAIR OFFICE DRAWING AND PLAN FILE | 14 | BOATSWAINS STORES | 19 | 36" x 72" OPENING | 24 | 72" x 72" OPENING | | |
| 5 | DOCTOR'S OFFICE DISPENSARY | 10 | 3 TON ELEC. TRAVELING CRANE W/ CAD CONTROL | 15 | 36" x 66" OPENING | 20 | GENERAL WORKSHOP (SHIPS) TESTING LAB AND BURNER CLEANING SHOP | 25 | MASTER AT ARMS S.R. | | |

USS Vulcan

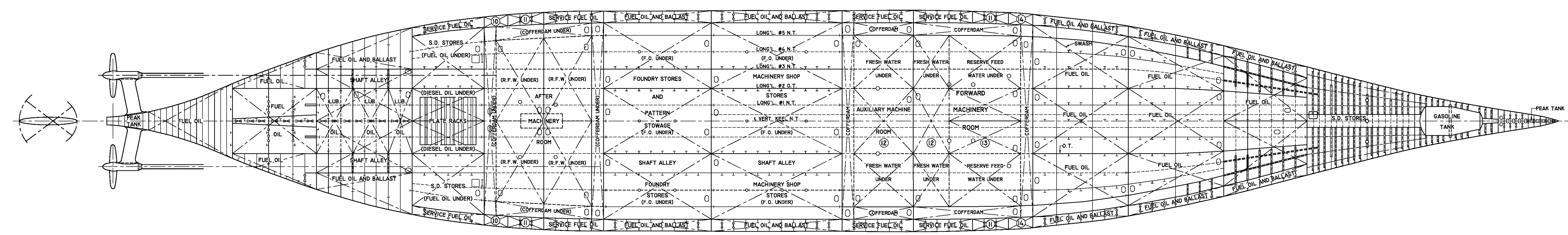
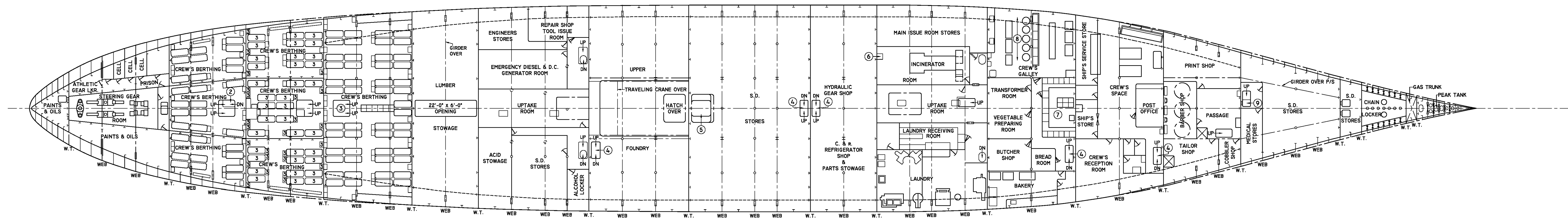
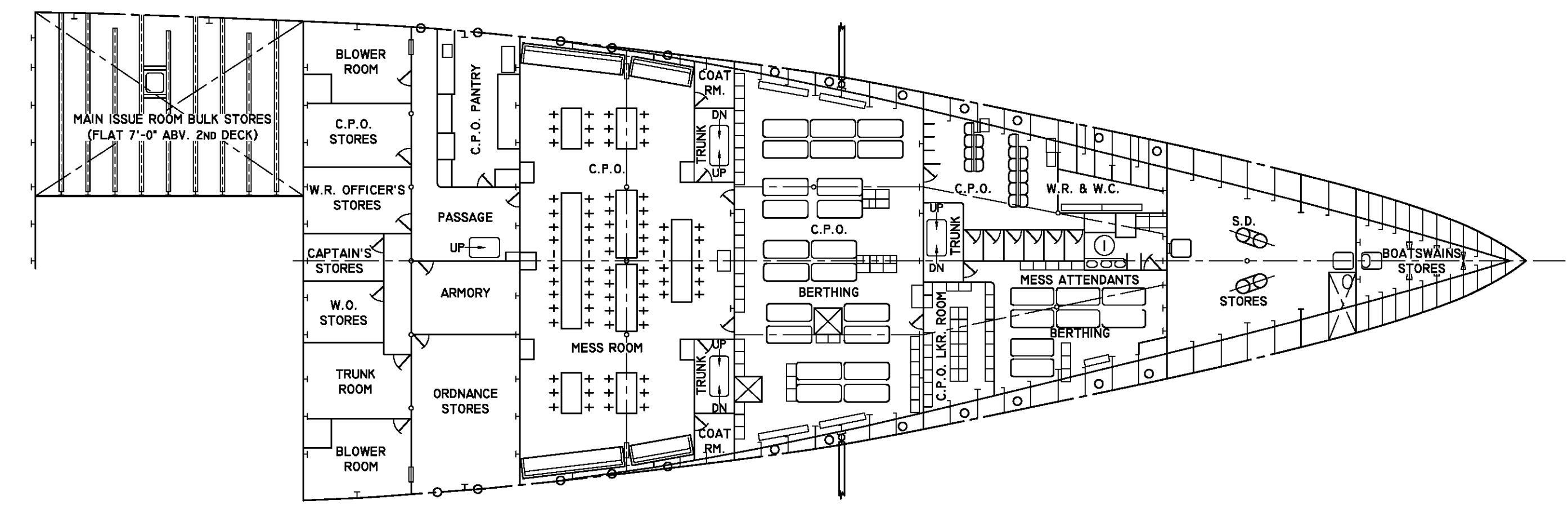

NOTE: DRAWINGS TRACED FROM SCANS OF ORIGINAL DESIGN DRAWINGS (GENERAL ARRANGEMENTS MCI919-S33-I-15)

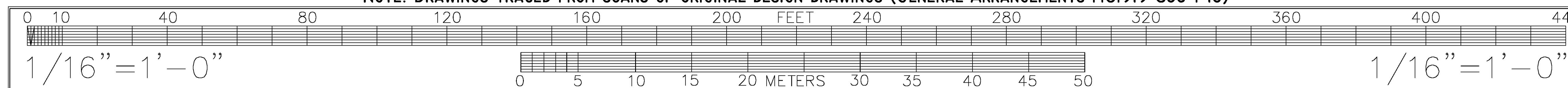

SCHEDULE OF ROOMS & FEATURES OF VESSEL

| NO. | NAME/ TITLE | NO. | NAME/ TITLE | NO. | NAME/ TITLE | NO. | NAME/ TITLE |
|-----|-----------------------------|-----|-----------------------------------|-----|---------------------|-----|--------------------------|
| 1 | MESS ATTENDANTS W.R. & W.C. | 5 | 7'-6" x 8'-0" F.N.T.H. | 9 | 36" x 30" HATCH | 13 | RESERVE FEED WATER UNDER |
| 2 | 30" x 84" OPENING | 6 | 24" x 24" CHUTE FROM SUPER DECK | 10 | OVERFLOW TANK | 14 | F.O. OVERFLOW |
| 3 | 72" x 72" HATCH | 7 | PROVISION ISSUE ROOM | 11 | SETTLING TANK | | |
| 4 | 36" x 72" OPENING | 8 | 80 GALLON STEAM JACKETED ICE TUBS | 12 | POTABLE WATER UNDER | | |

USS Vulcan

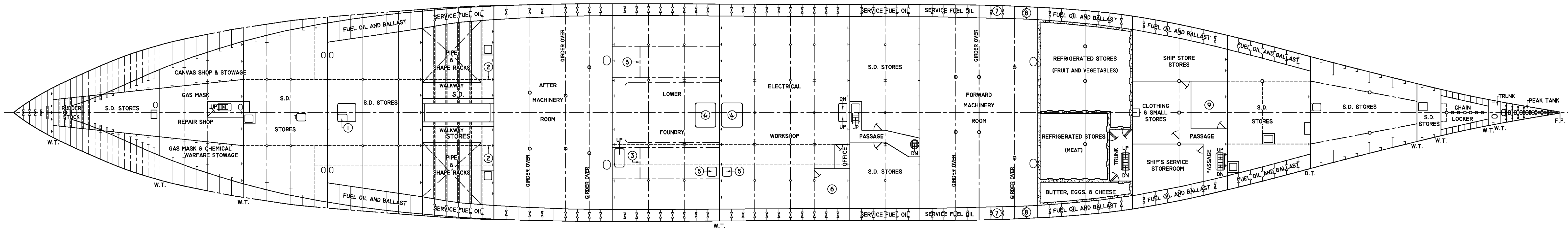

FIRST PLATFORM

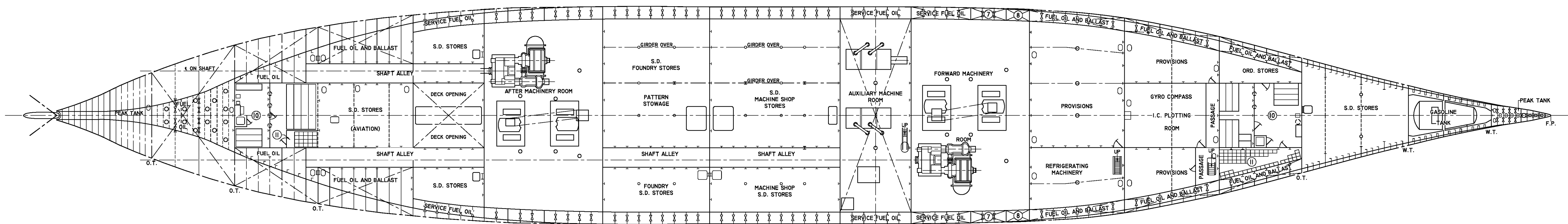

SECOND PLATFORM

NOTE: DRAWINGS TRACED FROM SCANS OF ORIGINAL DESIGN DRAWINGS (GENERAL ARRANGEMENTS MCI919-S33-I-15)

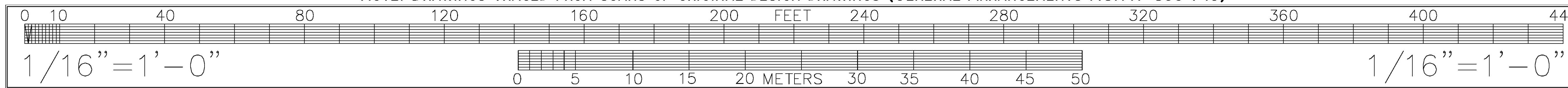

SCHEDULE OF ROOMS & FEATURES OF VESSEL

| NO. | NAME/ TITLE | NO. | NAME/ TITLE | NO. | NAME/ TITLE | NO. | NAME/ TITLE | NO. | NAME/ TITLE |
|-----|--------------------|-----|------------------------|-----|-----------------------------------|-----|------------------------|-----|---|
| 1 | 30" x 36" HATCH | 3 | ½ TON CRANE OVER | 5 | 36" x 36" F.N.T.H. | 7 | SETTLING TANK | 9 | CLOTHING AND SMALL STORES ISSUE ROOM |
| 2 | WALKWAY (PORTABLE) | 4 | 7'-0" x 8'-0" F.N.T.H. | 6 | PARTS STOWAGE AND TOOL ISSUE ROOM | 8 | FUEL OIL OVERFLOW TANK | 10 | 5" HANDLING ROOM AND PROJECTILE STOWAGE |
| | | | | | | | | II | SMALL ARMS MAGAZINE |