

**NOTE:**

THIS PLAN IS FOR GUIDANCE OF BIDDERS ON V2145, CONVERSION OF BCVE CARRIER FOR SEAS SHIPPING CO. ALTHOUGH THIS PLAN IS FOR AN AVG (BASED ON A C3-S-A2), IT IS GENERALLY SIMILAR TO A BCVE, (BASED ON A C3-S-A1).

HNSA thanks Ed Zajkowski for his generous loan of the original document used to create this online version.

**ALTERATIONS**

NO.	DESCRIPTION	MADE BY	DATE
1	PLAN REDRAWN AND BROUGHT UP TO DATE TO SUIT HULLS NOS. 295 & 296	M.E.K.	1/25/43
2	BU SHIPS NO. ADDED	M.E.K.	5/5/43

**PRINTS ISSUED**

Alterations	1
Date issued	7/43
B'ham Off	2
Blacksmith	
Carpenters	2
Chip & Caulk	
Class Soc	1
Coppersmith	2
Electricians	4
Eng. Drawing	
Fab. Shop	2
Hull Eng	6
Hull	6
Joiners	2
Mach. Shop	2
Mach. Supr	6
Mould Loft	2
Navy Dept	4
N. Y. Office	2
Order Dept	2
Out. Mach	2
Qual. Supr	6
Orders Rep	5
Painters	2
Pipe Shop	2
Fishing	2
Plant Engr	
Purchasing	
Riggers	1
Sheet Metal	5
Shipfitters	5
Stee. Yard	
U. S. M. C.	8
Welders	
Mr. Plan	1
Mr. Swigert	1
FILE	153

**REFERENCES PLANS**

NO.	PLAN NO.	PLAN TITLE
1	1601-8	INNER BOTTOM & HOLD - COMPT. & ACCESS & DECK SUPPORTS.
2	1601-9	2 <sup>ND</sup> PLATFORM & PLATS IN HOLD - COMPT & ACCESS & DECK SUPPORTS
3	1601-10	2 <sup>ND</sup> DECK & 1 <sup>ST</sup> PLATFORM - COMPT & ACCESS & DECK SUPPORTS.
4	1601-11	MAIN & FORECASTLE DECKS - COMPT. & ACCESS & DECK SUPPORTS
5	1601-12	GALLERY DECK, NAVIGATING BRIDGE & WALKWAYS & GUN PLATFORMS - COMPT. & ACCESS & DECK SUPPORTS.
6	1601-13	FLIGHT DECK - COMPT & ACCESS.
7	1601-14	INBOARD PROJECS - COMPARTMENT & ACCESS & DECK SUPPORTS

**BU SHIPS NO. ACV6 -S0103-12043 ALT.**

**THE INGALLS SHIPBUILDING CORPORATION  
PASCAGOULA, MISSISSIPPI**

INGALLS HULL NOS. 293, 294, 295, 296,  
AUXILIARY AIRCRAFT CARRIERS, ACV-6, ACV-8, ACV-10, ACV-17.

**GENERAL ARRANGEMENT**

DRAWN BY G.E.M. 7/28/42. TRACED BY: MEK. 1/25/43. SCALE 1/6" = 1 FT.

**PLAN NO. AVG-P9-0-1**

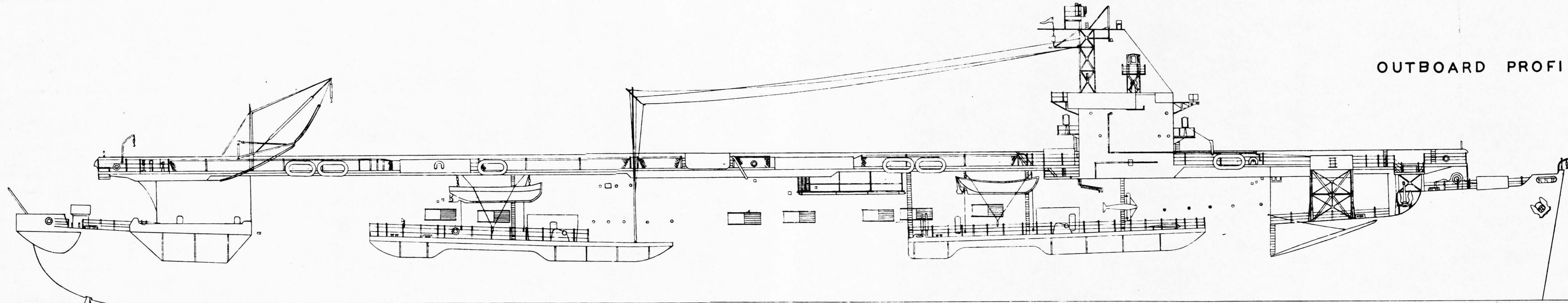

OUTBOARD PROFILE

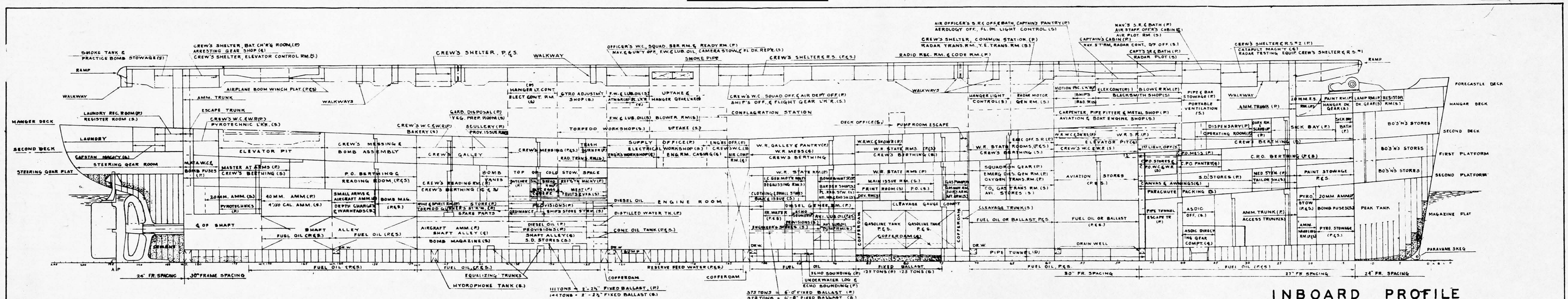

# INBOARD PROFILE

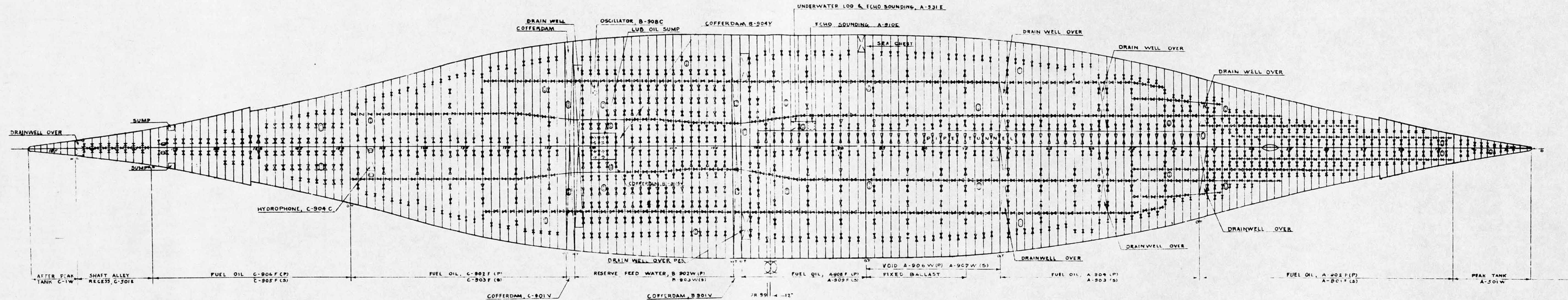

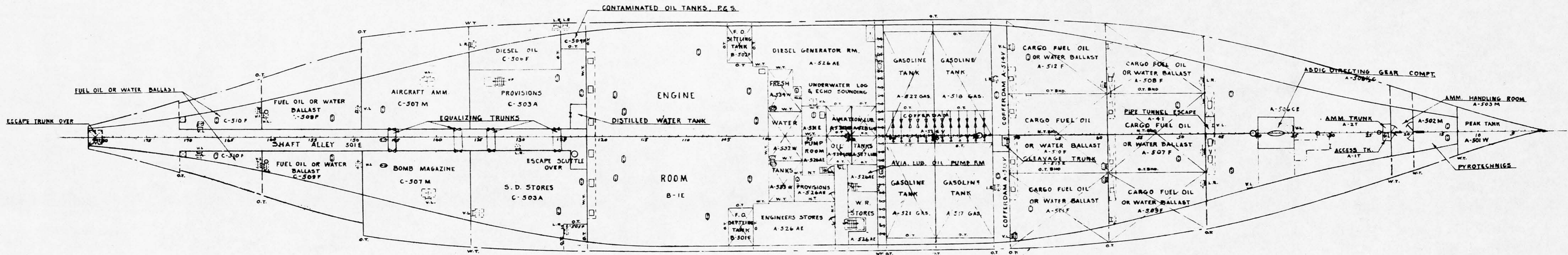

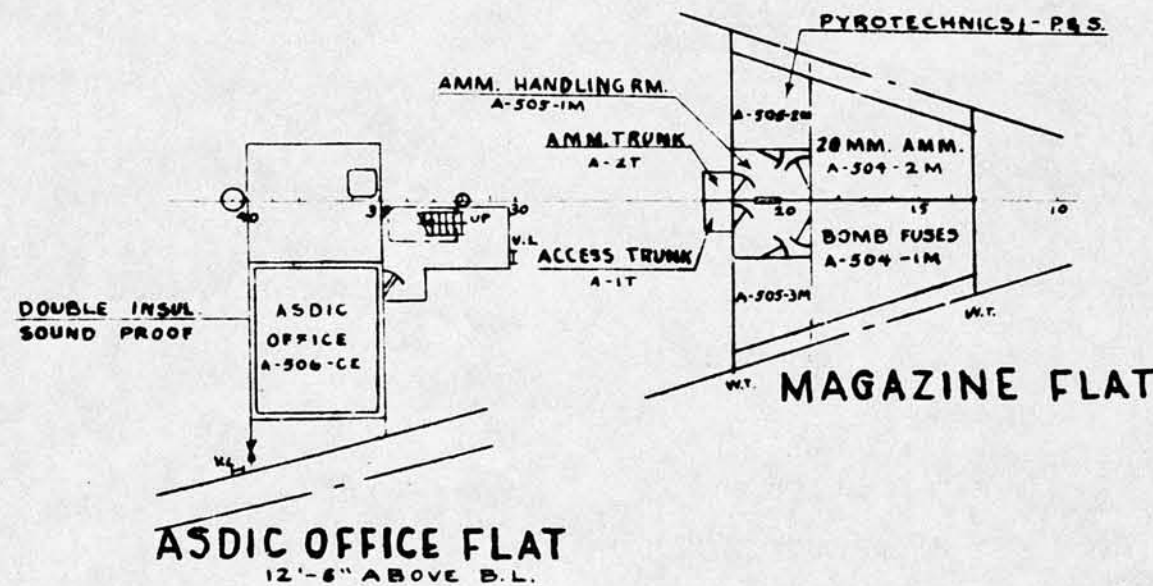
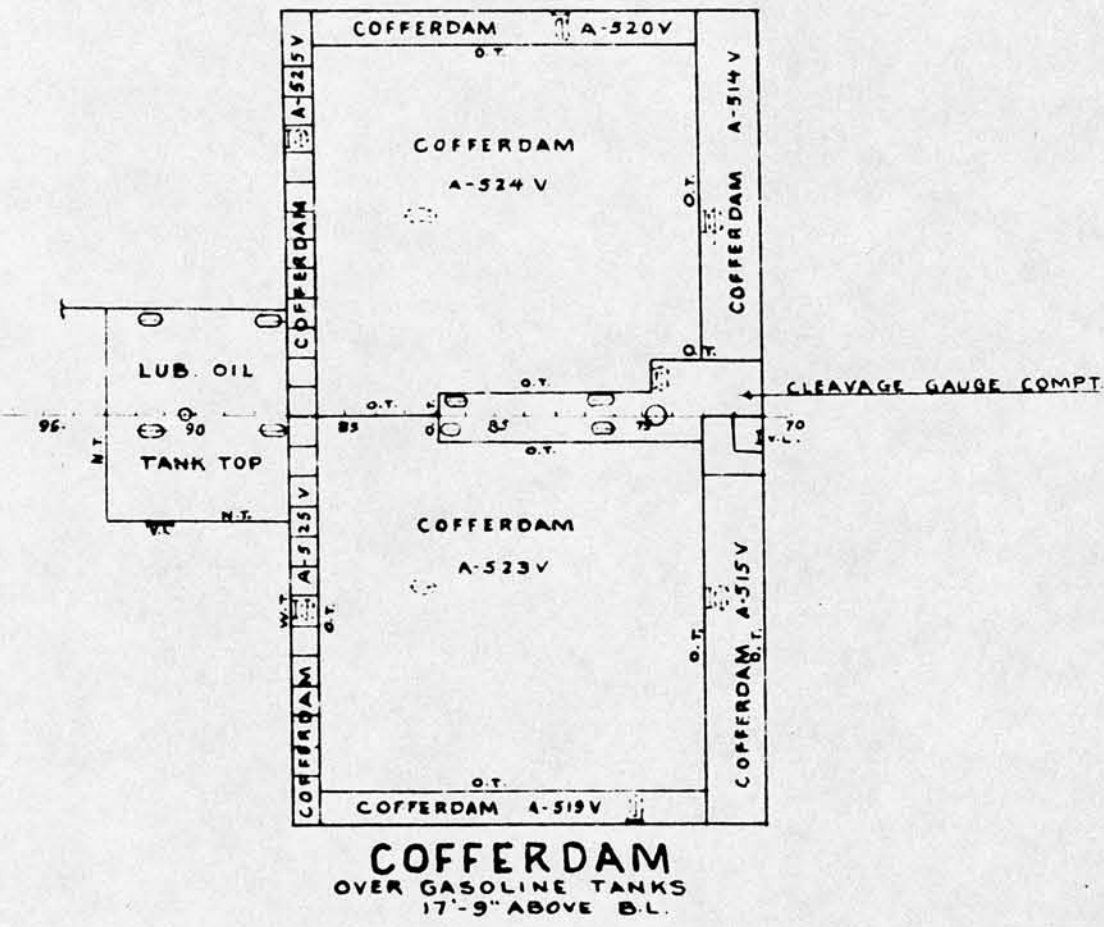
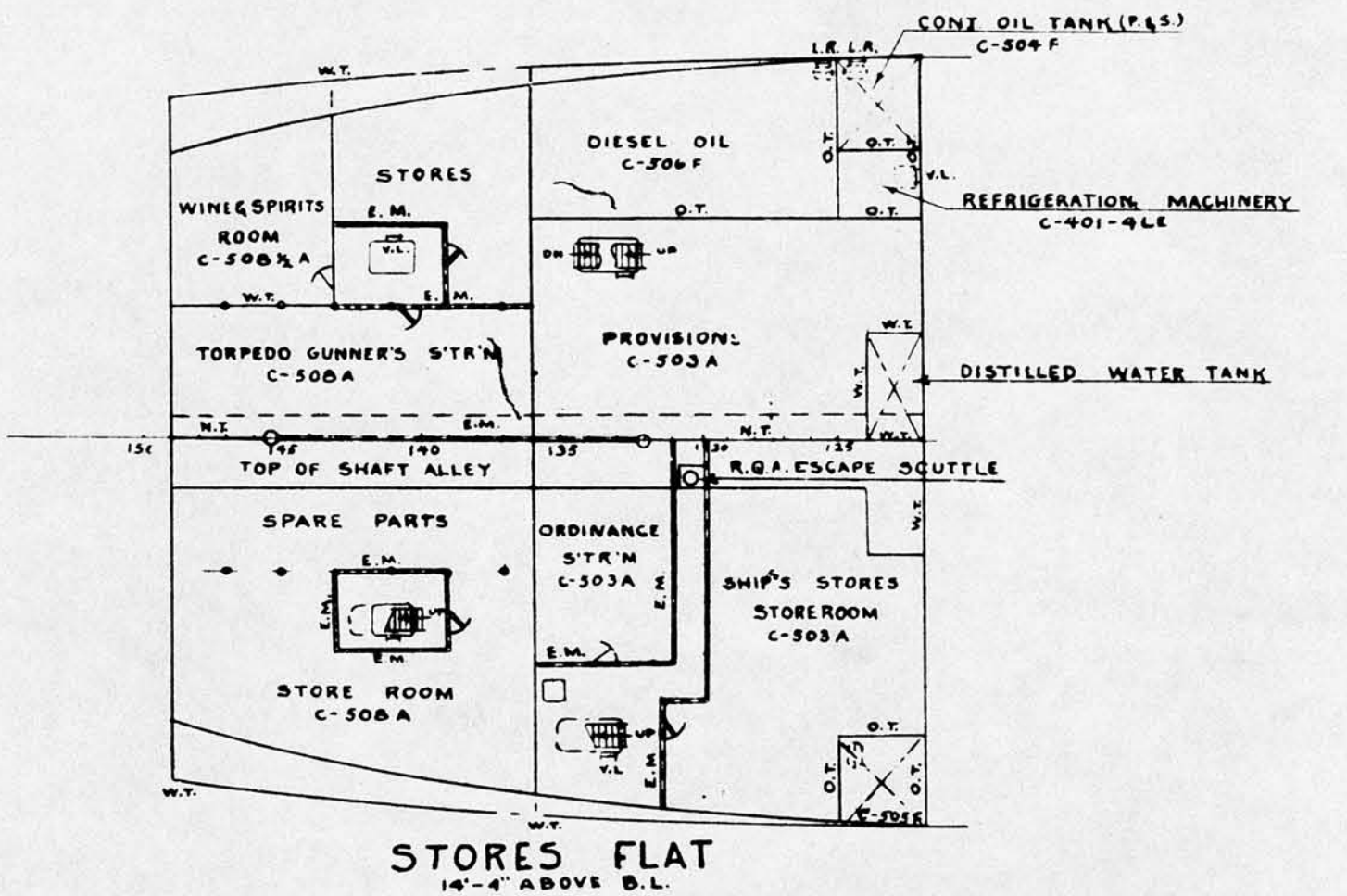

**ASDIC OFFICE FLAT**  
12'-6" ABOVE B.L.

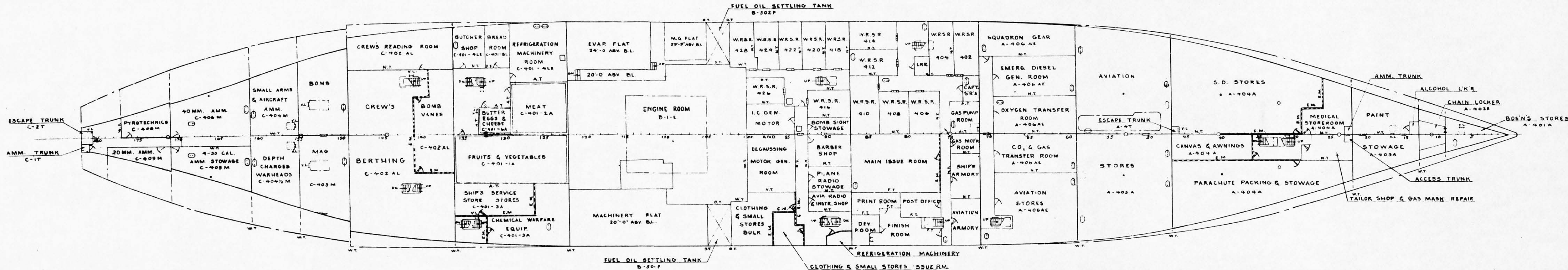

# SECOND PLATFORM

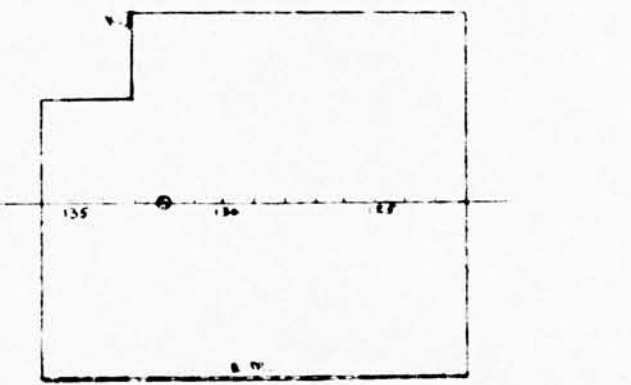
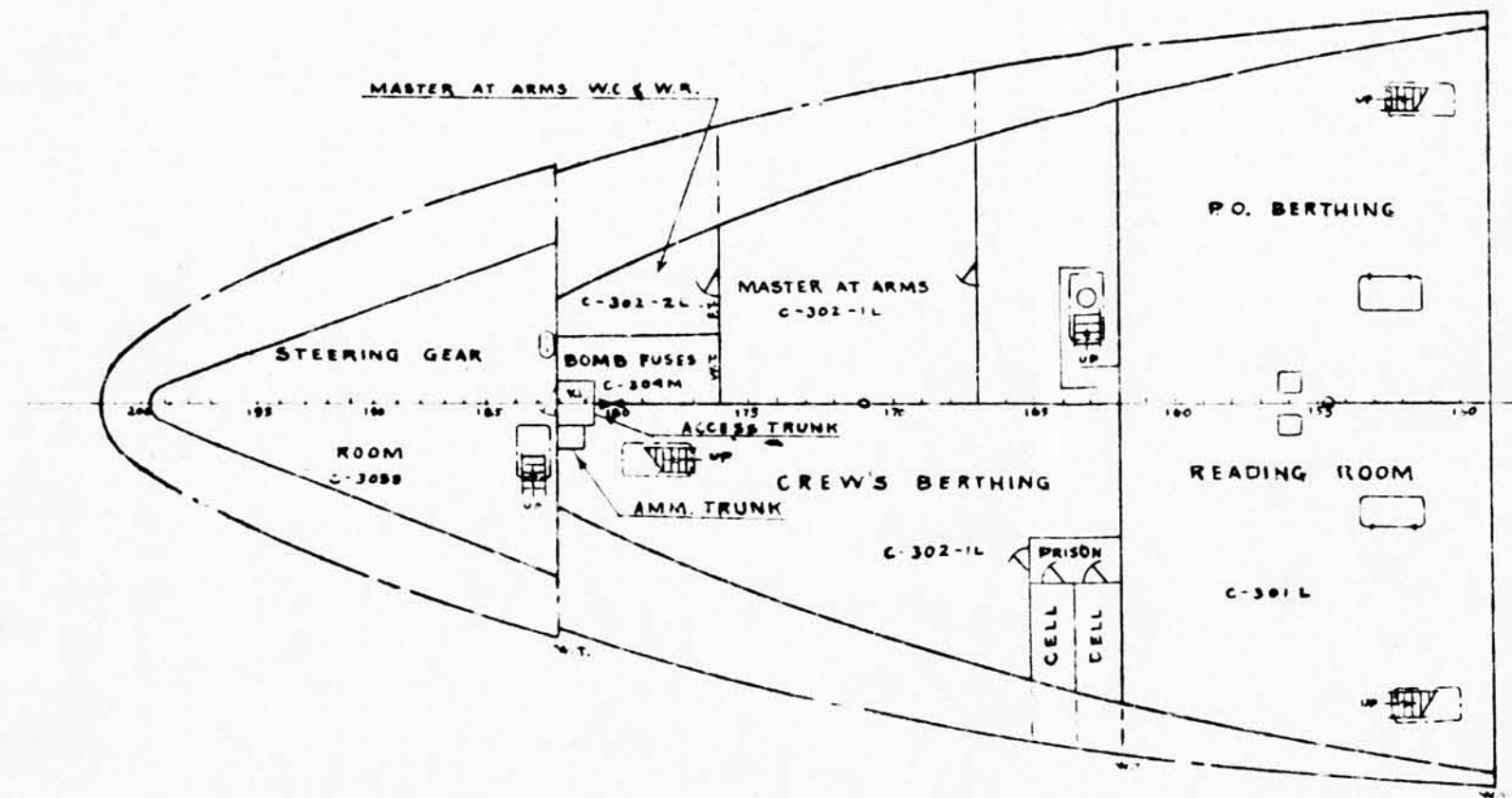

TOP OF COLD STORAGE SPACE

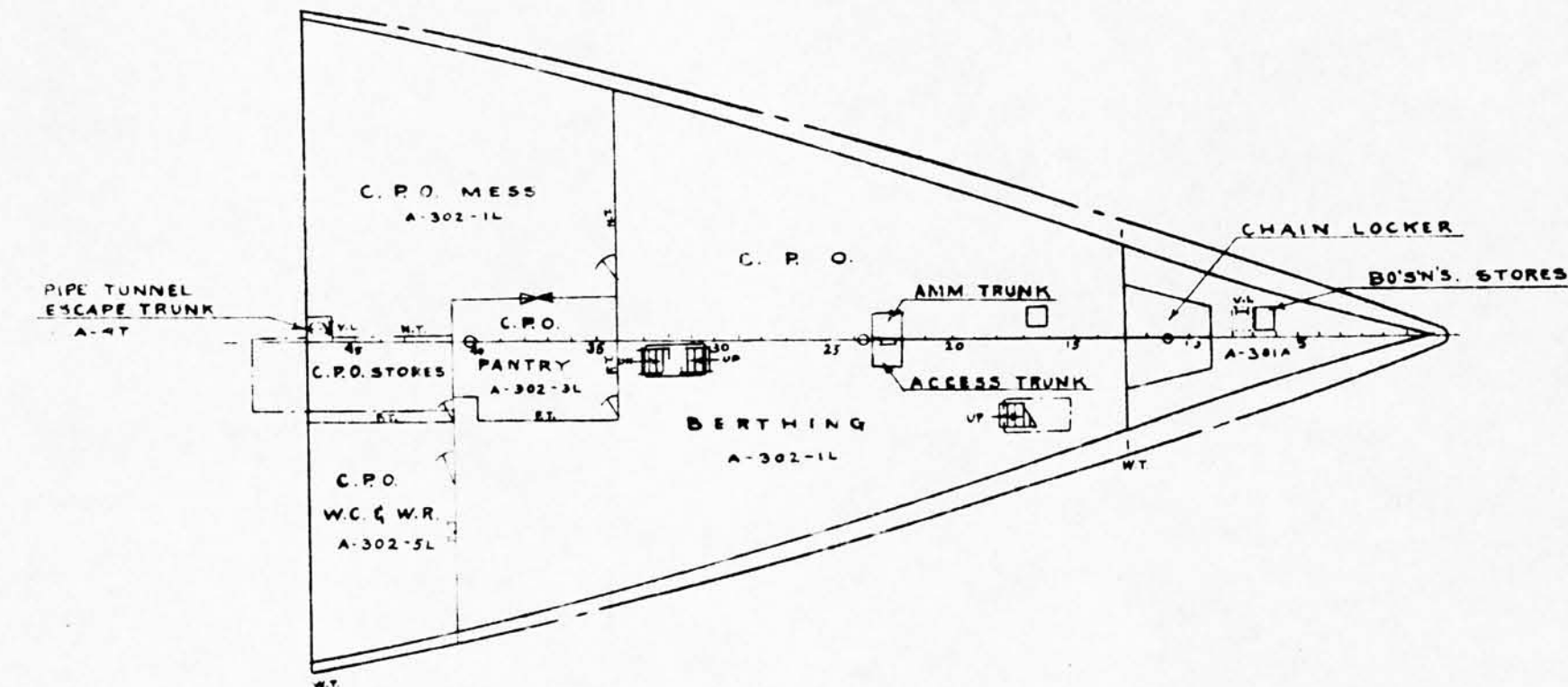

FIRST PLATFORM



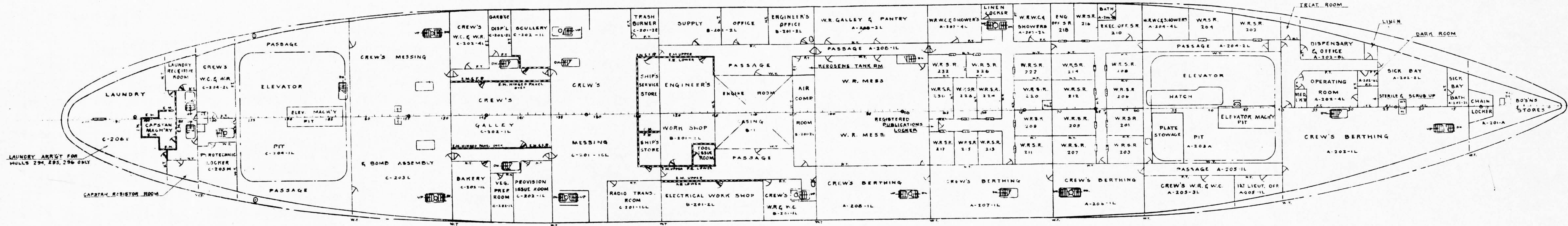

SECOND DECK

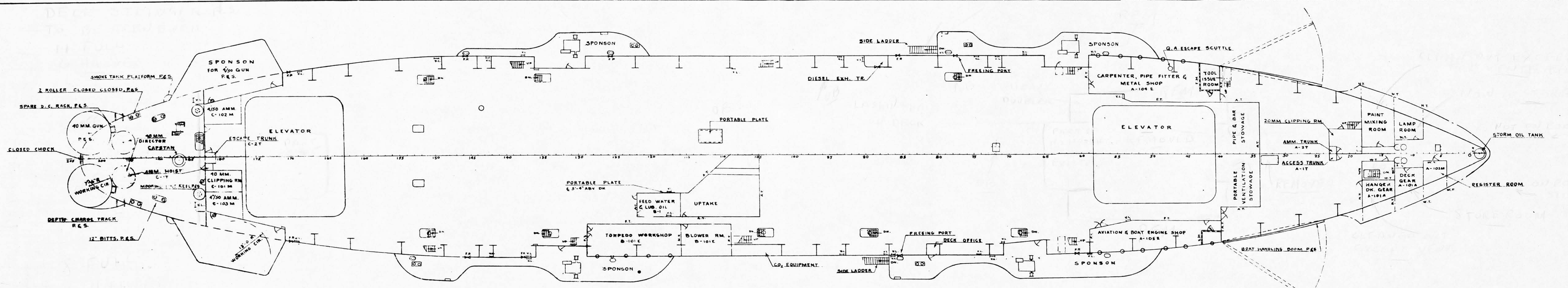

**HANGAR DECK**  
 SHEET 10 OF 15

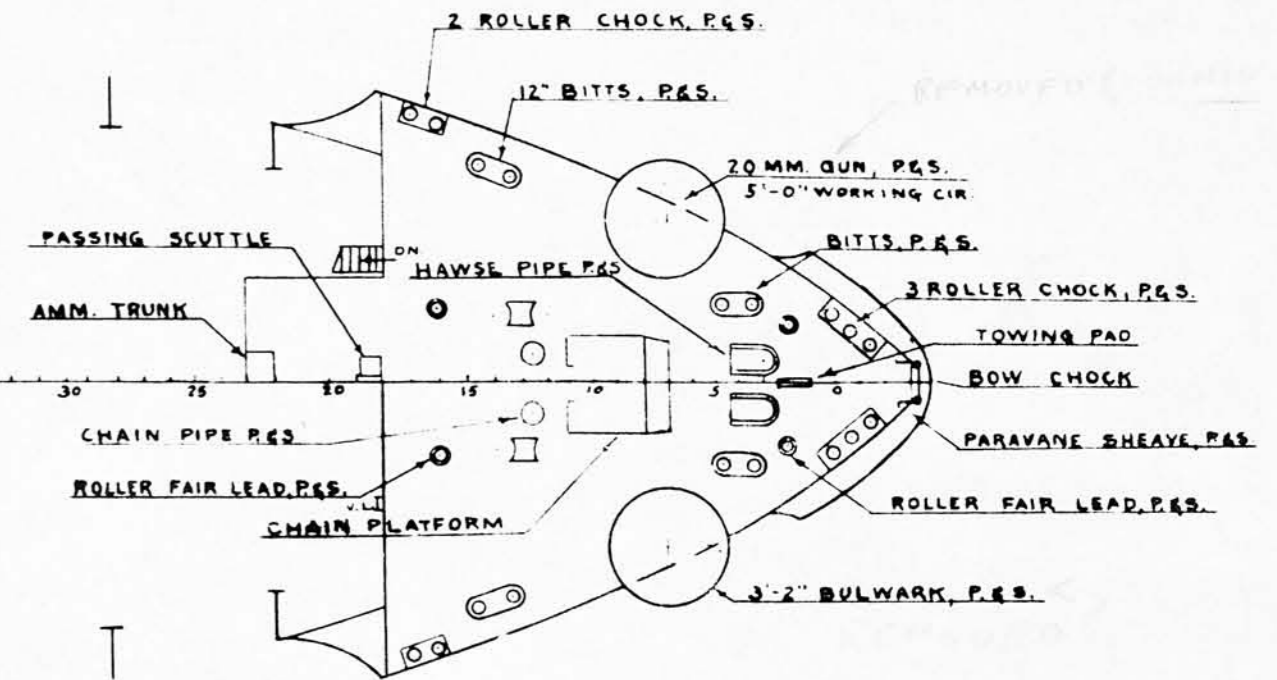
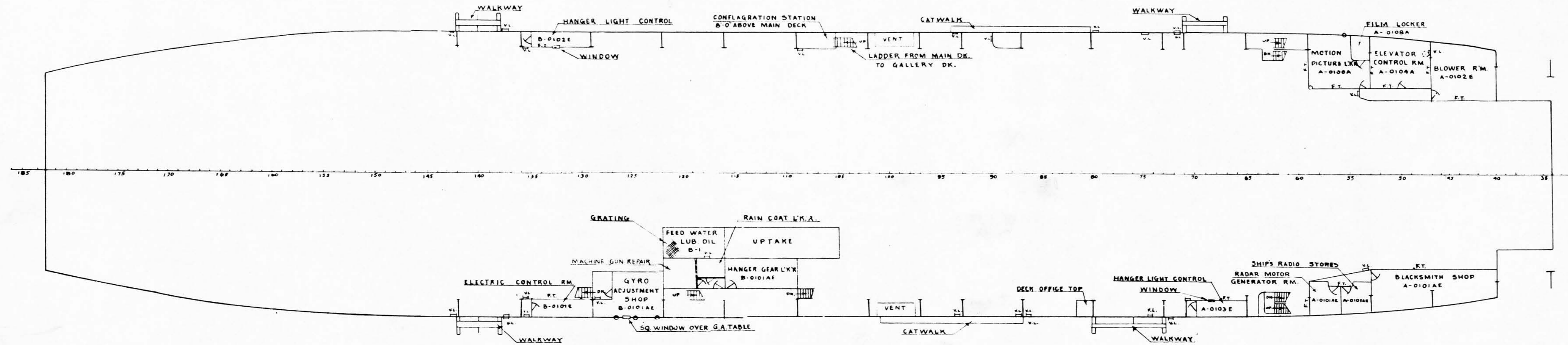

**FORECASTLE DECK**  
SHEET 11 OF 15

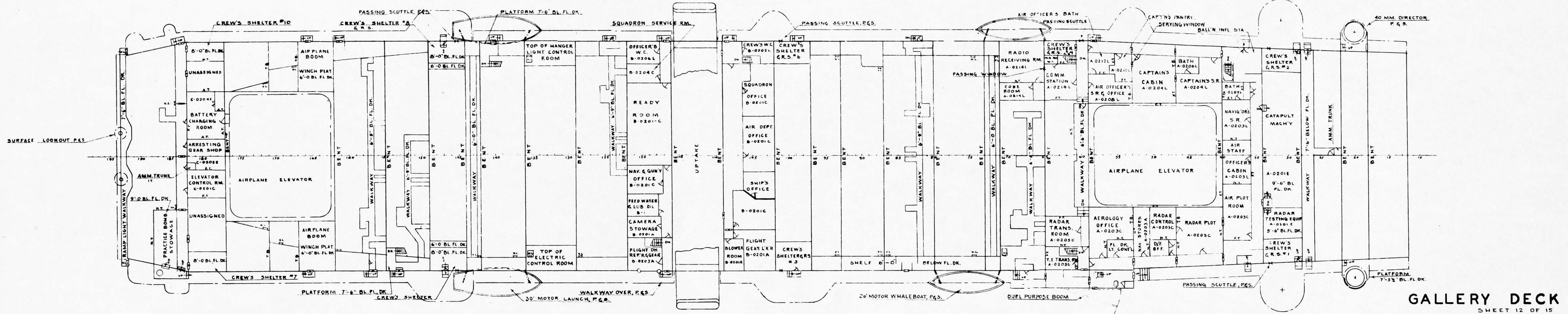

**GALLERY DECK**  
SHEET 12 OF 15

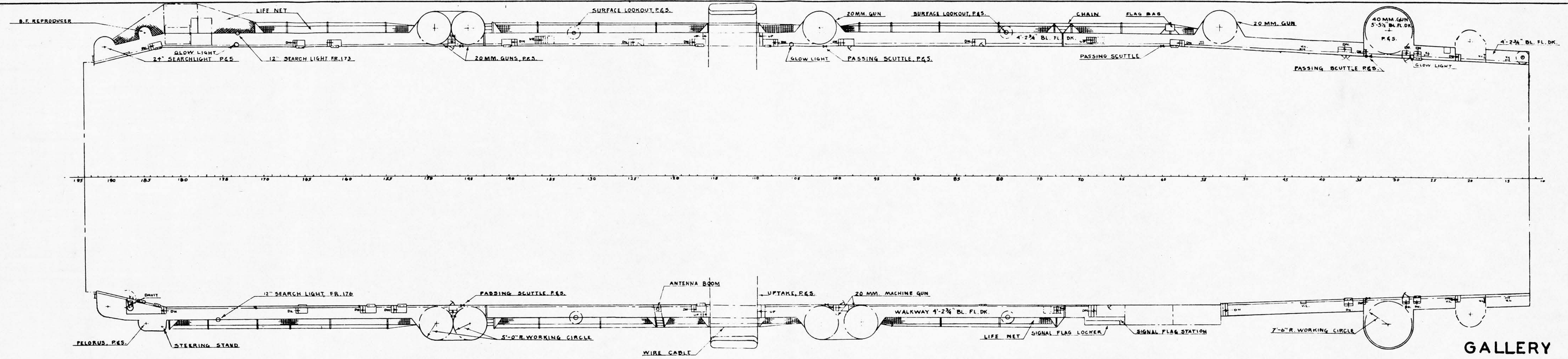

**GALLERY WALKWAYS**  
 SHEET 13 OF 15

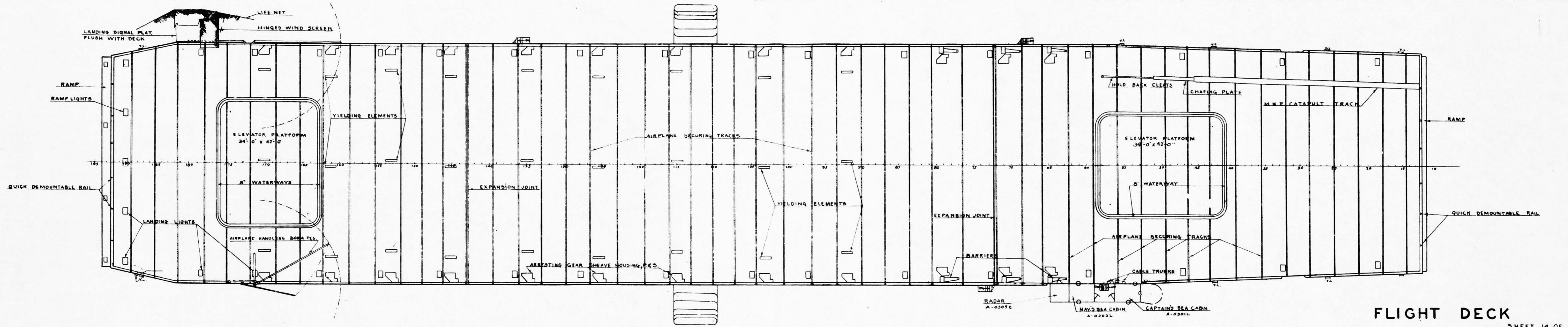

# FLIGHT DECK



**TOP OF MAST**

110'-11 1/4" ABOVE B.L.

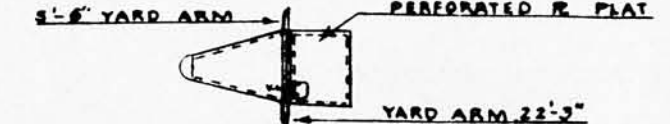

**2<sup>ND</sup> MAST PLAT.**

104'-11 1/4" ABOVE B.L.

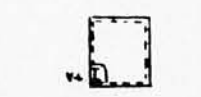

**1<sup>ST</sup> MAST PLAT.**

97'-9 3/4" ABOVE B.L.

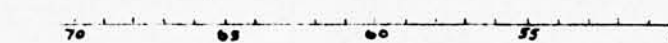

**AERIAL ENCLOSURE PLAT.**

97'-3/4" ABOVE B.L.

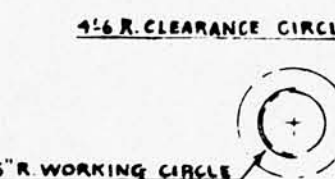

**RANGEFINDER PLAT.**

87'-5 3/4" ABOVE B.L.

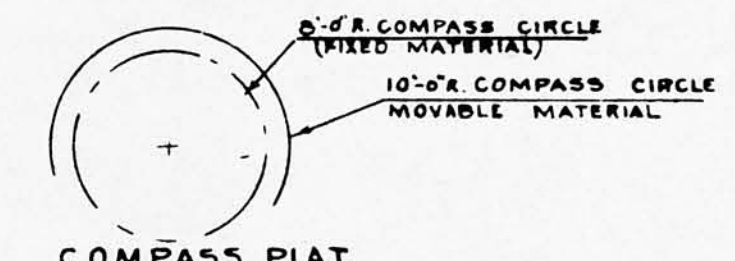

**COMPASS PLAT.**

90'-6 3/4" ABOVE B.L.

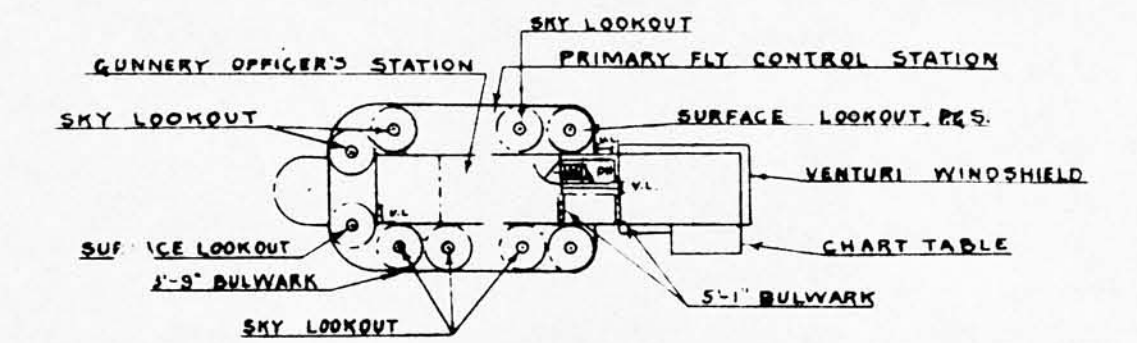

**OPEN BRIDGE**

85'-5 3/4" ABOVE B.L.

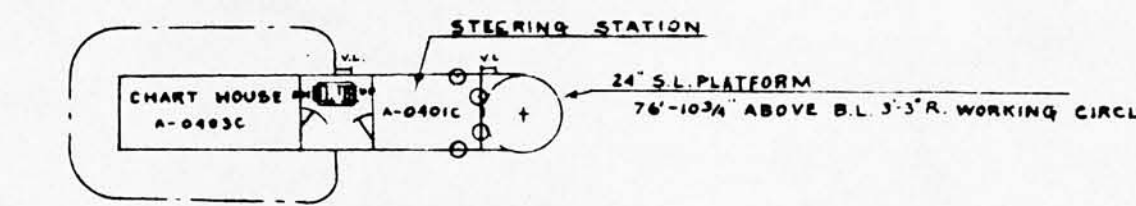
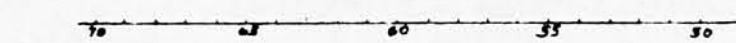

**NAVIGATING LEVEL**

78'-5 3/4" ABOVE B.L.

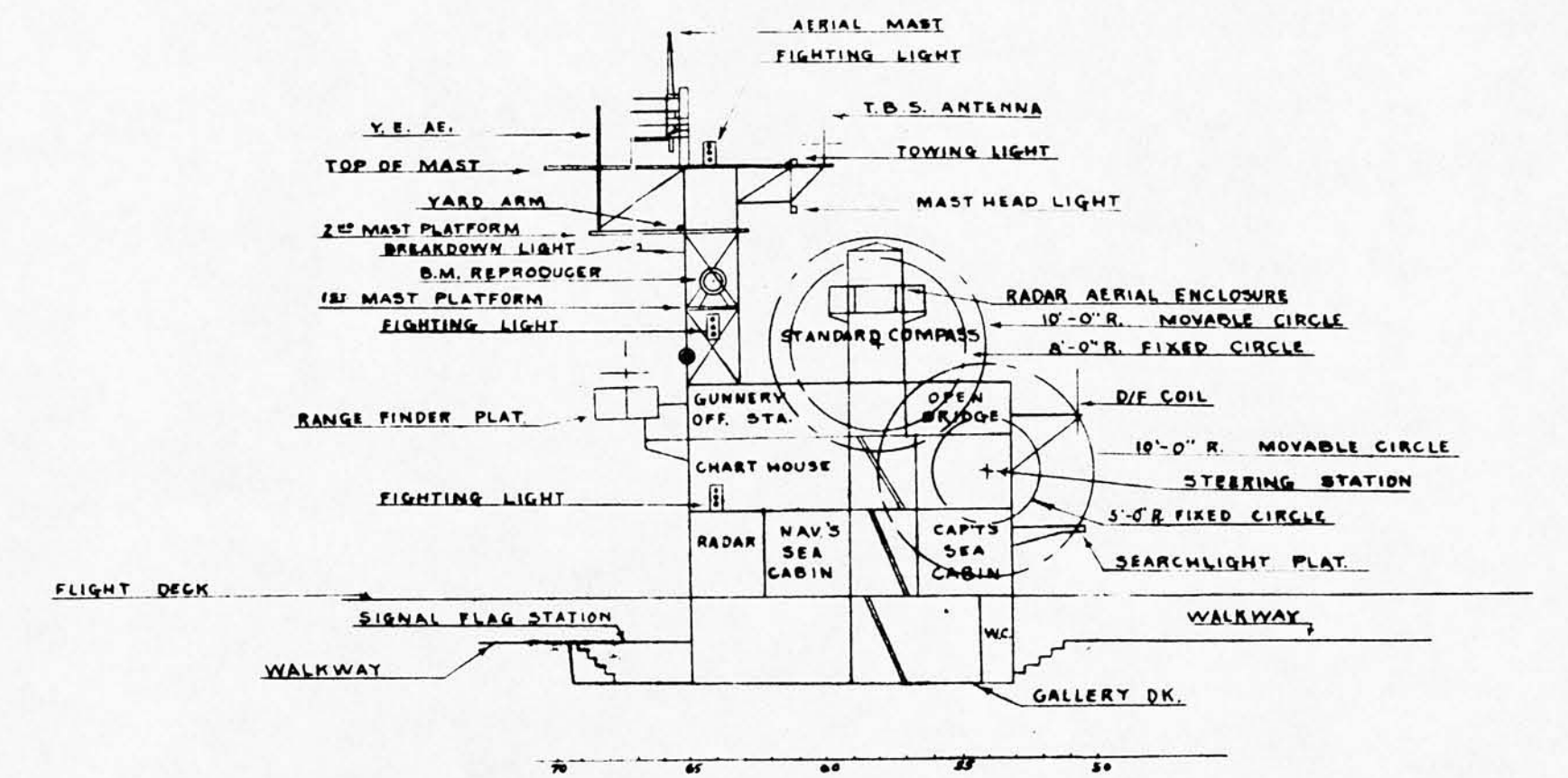

**INBOARD ELEVATION OF ISLAND STRUCTURE**

**ISLAND STRUCTURE**